

A photograph of the Aurora Borealis (Northern Lights) in shades of green and blue, dancing over a dark, snow-covered mountain range under a starry night sky. The aurora is the most prominent feature, with bright green bands and curtains of light. The mountains below are dark and rugged, with patches of snow. The sky is a deep, dark blue-green, filled with numerous small, bright stars.

ENGINEERS INSIGHT

Volume 27

December 2021

Engineers Insight Editorial Board



Ts. Harvin Kaur



Ir. Ts. Dr. Lau Chee Yong



Ts. Dr. Shankar Duraikannan Prof Ir. Ts. Dr. Vinesh Thiruchelvam

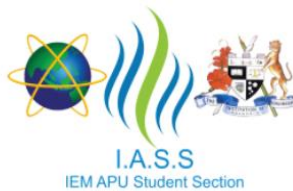

APU MALAYSIA
STUDENT CHAPTER



**Institution of
MECHANICAL
ENGINEERS**

Table of Content

No.	Item	Page Number
1	Year End Message by Assoc. Prof. Dr. Thang Ka Fei	4 & 5
2	Article: Change Management in the Education Industry by Ts. Harvin Kaur	6 – 8
3	SoE Webinars	9
4	SoE Events	10 – 21



“Victory comes from finding opportunities in problems”

Assoc. Prof. Dr. Thang Ka Fei, Head of School, SoE

Year End Message by HOS

ASSOC. PROF. DR. THANG KA FEI
DECEMBER 2021

Merry Christmas and a Happy New Year 2022 in advance. As the year of 2021 has drawn to an end, perhaps it is appropriate for us to reflect on past happenings and to develop wishes for the upcoming 2022. Reflect back, 2021 has continued to be challenging for students and staff alike as we were in lock-down for good six months; academic activities have to be conducted via Open & Distance Learning (ODL) and we were not able to meet each other physically. Some of us may have friends and family members who have their health affected due to the Covid-19 pandemic. In summary, it has been a rough and bumpy ride in 2021. However, as Sun Tzu, the author for the “The Art of War”, once said: “victory comes from finding opportunities in problems.”, we must reflect on past happenings and mistakes committed and proceed to strategize for success in the new year. It is important that we learned from the past to plan for the future and to ensure that we are able to make progressive improvement to our life and to people around us. .

For those of you that have made the resolution list for 2022, I would be glad to hear from you on what they are, do drop me an email or MS Teams message! And for those who have not decided on what those resolutions are, I would like to offer a few suggestions that you may want to add to your list.

1. Be a Go-Getter. A go-getter is a person that is energetic, determined to be successful and able to cope with new or difficult situations. Let’s reflect on what had happened in 2021; how often have you delayed starting on your assignment till the very last moment? And, how often were you absent from your ODL classes? A go-getter person will be self-initiated and proactive in everything they do and typically they will also obtain good grades in their study. You can vow to be a go-getter in 2022!
2. Be a Good Time Manager. Typical University students’ life is bustling with studies and personal activities that are relaxing. It is quite easy to lose focus and be lopsided with too much enjoyment and hence not contributing positively to your academic development. An enjoyable University experience should evolve around a balanced diet of both, which involves no other than good management of your available time. For 2022, my suggestion is for you to list down all activities, starting from weekly to monthly, and start assigning priorities to them. With that, you will soon realize that you have enough time for everything you wanted to do and be good in doing them as well!

2. Try something new! Looking back at 2021, have you participated in any online activities (e.g., talks, workshops, virtual-visits, and competitions)? If you have not, 2022 will be the year where you will vow to make a change! Activities that have been highlighted are beneficial for your exposure to real-world engineering and will polish up your CV with excellent highlights. And, with the pandemic easing into endemic hopefully in 2022, the School of Engineering will organize more physical activities that are both enjoyable and educational.
3. Connect and Engage. If you have not been seeking consultation from lecturers in 2021, now there are plenty of opportunities to do so in 2022. Having to connect with your lecturers and engage in consultation in and out of lectures are vital for your success in class-tests, assignment and final exams. In addition, you should connect with classmates and actively engage in group discussion both online and physically; you will soon discover that this helps in completing your assignments and design activities much faster and with better quality than doing it alone!
4. In summary, you have made a commitment to improve if a resolution is made; your resolution should be realistic and making progressive improvement is fine. If you have not made any resolution do consider my suggestion above. All the best in 2022!

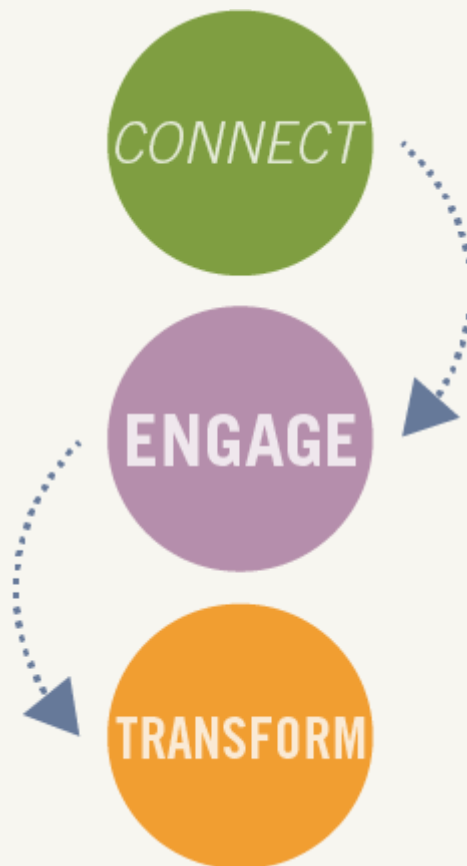



“Higher education management is a paradox when it comes to change management.

Ts. Harvin Kaur, Lecturer, SOE

Change Management in the Education Industry

TS. HARVIN KAUR
DECEMBER 2021

In last decade, the universities characteristics has thoroughly transformed. The universities transformation includes teaching delivery mode, financial self-sufficient, organizational structure, organizational decision-making processes (e.g., leadership strategies and strategic planning dynamics) and organizational culture. Uncertainty in government funding, greater competitions and increased in globalization are driving universities to re-examine their governance structure and consider ways to set themselves coping with fast-changing market forces. Universities must implement changes at all levels of the organization. These new forces that are causing significant shifts impacted higher education goals, processes, and decision-making which influences change management in universities. Higher education management is a paradox when it comes to change management. Effective higher education management is a global challenge because it is a volatile field in which new ideas, solutions, and practices are constantly evolving based on current transdisciplinary and interdisciplinary studies. Changes in higher education management are generally supported by the university members when there are research data contradicting with the current beliefs or ideas.

However, there are a group of professors and managers in higher education still consider it is difficult to change their practices and behaviors, despite the presence of research findings recommending the universities to change. Executive coaching has been employed in this context to help university leaders (with strong change resistance) achieving more clarity in their professional careers, increase their level of personal awareness, improve their skillset, and lower their change resistance level. The goal of executive coaching is to help university leaders to reach their full potential and take the universities to the higher level of quality education. However, despite executive coaching, the higher education institutions have still a long way to go to achieve quality education. As higher education systems grow and diversify, society is increasingly concerned about the quality of programs. Much attention has been given to public assessments and international rankings of higher education institutions. Despite taking into account all the factors to improve quality of education, measuring quality in education is challenging and therefore, constant change is needed.

In Malaysia, higher education has undergone a paradigm shift in improving its standard since the legislation of Education Act 1996. The Act has been the foundation for the growth of Malaysian public and private higher education institutions (HEI). The higher education field in Malaysia has also gone through the similar change over the past decade. Private higher education providers in Malaysia have gone through huge transformation (e.g., advancements in technology, developments of research into teaching and learning, increased requirements of skills and knowledge, core competencies, etc.) over the past decade.

Major changes have occurred throughout this COVID-19 pandemic that has resulted in temporary physical closures of schools and higher education institutions around the world. In higher education, approximately 220 million students globally have been affected due to the disruption caused by COVID-19, leaving policymakers and educational institutions with unprecedented challenges (e.g., mitigating learning losses, deploying remote learning, reopening educational institutions with the right SOPs, ensuring underrepresented, vulnerable, and disadvantaged learners are not left behind, etc.). The COVID-19 pandemic has already had an unprecedented impact on higher education worldwide in virtually all aspects of its functioning. In the academic year 2019/2020, the pandemic transformed the way teaching took place, accelerating transformation that was already taking place in the form of online learning and teaching. The pandemic has also had direct impact on how research is carried out, on university operations (e.g., campus closures and the shift to online learning) and on university governance, with management staff needing to take a range of emergency decisions and allow additional flexibility in many areas of activity.

The COVID-19 pandemic and its extensive implications continued to unfold in many sectors globally. The higher education system was one of the first to be affected by lockdown and social distancing strategies. Universities are indeed a place where many people from different countries meet and are therefore, highly risky for the spread of COVID-19 (World Health Organization, 2020). In April 2020, schools and Universities were closed in 191 countries and these measures affected over 1.5 billion learners (i.e., 90.2% of total enrolled learners) (UNESCO, 2020). The “traditional” (face-to-face) higher education system was unprepared for the lockdown (e.g., no plans for a massive shift to online teaching were available). After an initial phase, aimed at understanding whether the lockdown would only last a few weeks, most Universities replaced all face-to-face teaching with online education. Some higher education institutions were unprepared, while other universities that are proactively enhance their contingency plan upgrading online learning tools. There are four main areas that higher education providers’ staff struggles to cope with the challenges presented by the Covid-19 pandemic. First, they are learning to use the learning management system before conducting online class in the shortest possible time with little training and preparation. Strategies to adapt to online teaching was not developed and academicians was just expected to switch to online teaching. Second, some academicians do not subscribe to strong internet services at home. Third, academicians had to change the assessments to suit the online learning environment (e.g., converting the final exams to coursework) and take-home exams. Fourth, marking assessments online exposes academicians to computer vision syndrome as academicians had to use computers for long hours to read and provide feedback electronically. Preparing for the challenge of implementing change is difficult. Gaining a deeper understanding of the dynamics for organizational change and specifically the fundamental principles of implementing change would allow an organization to be better prepared to drive change. As challenges for change management gets tougher as the years go by, it is important that these challenges would ensure that change management is the catalyst for growth and keeps the higher education institutions stay competitive.



Education has changed dramatically with distinctive rise of online learning, where teachings are done remotely on digital platforms. To remain relevant, universities will need to reinvent learning environments so that digitalization expands and complements, but does not replace, student teacher and student-student relationships. With the enrolment of students for the next academic year severely compromised, this will cut into universities' bottom line, affecting not only their core education services, but also the financial support they provide domestic students, as well as research and development activities. Private institutions too, may be under threat of reduced funding. On the flipside, the pandemic could also prompt reform in fee structures and creation of more cost-effective programs. There is an opportunity to rethink the traditional education system now. There are several needs for change management. Change management can lead to many changes if the organization decides to adopt a new distribution methodology. The introduction of new technologies is also another internal force for change which affects an organization. The implementation of new technology needs new processes or structures. Through this, employees will have to be trained for new processes. The composition of an organization's workforce never stays static as it changes in terms of gender, age, or education. New employees join the organization, and the turnover of staff is also another need for change management. With these changes, senior management may need to redesign work to ensure the job requirements match the skills of the employees.

Despite this focus, the practice of organizational change remains in its early stages. Change management experts have emphasized the importance of establishing organizational readiness for change and recommended various strategies for creating it. Although the advice seems reasonable, the scientific basis for it is limited. Unlike individual readiness for change, organizational readiness for change has not been subject to extensive theoretical development or empirical study. One indication of this is the fact that scholars and practitioners have no common definition of organizational change or common taxonomy. For example, when some organizations speak about change, they are referring to an internal process for implementation and often referred to as change management. Change management activities are not focused on changing the market, but on reacting to market changes. The difference between good and great change management hinges on the ability of an organization to react to market changes quickly, effectively, and with fewer resources than its competitors. Many project plans are often centered around technology and not people or process. Decades of scientific research into motivation indicate that a growth mindset, which holds that skills and abilities can be improved in ways that shape the purpose of the work that you do, leads to academic achievement, relational fulfillment, and professional success. And while the idea has spread rapidly like wildfire across forward-thinking organizations, it has been criminally understudied in the field. Organizations, as well as individuals, must be committed to the concept of lifelong learning and continual growth and development.

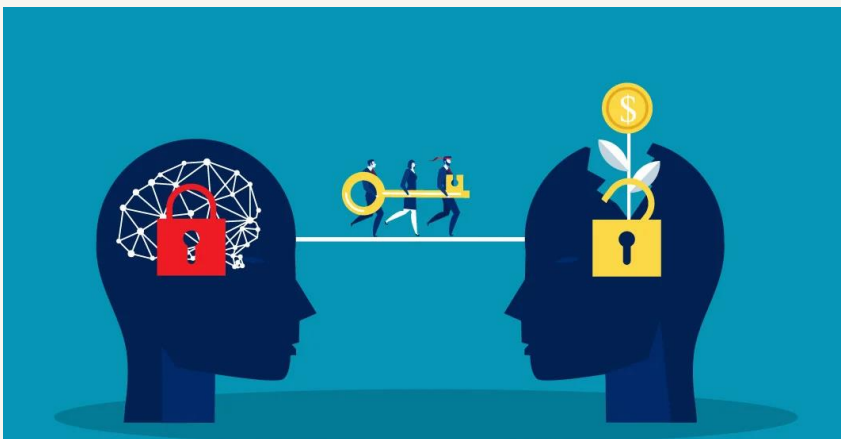

APU MALAYSIA
STUDENT CHAPTER

Institution of
**MECHANICAL
ENGINEERS**

Institution of Mechanical Engineers (IMechE)

TECHTALK SERIES 2

DR. ARUN SEERALAN
SEPTEMBER 2021

This is a series of talks hosted by IMechE APU SC to promote several engineering topics to the students of APU. As of now, in the series there has been 3 talks and 1 workshop, on topics such as “Disruptive Engineering”, “Emulsion” and “Suspension Systems”. The series started with a workshop on System modelling and Analysis with Simulink on the 7th of August by CEng Ts. Dr. Shankar Duraikannan. Afterwards was the talk on Engineering by CEng Ts. Dr. Shankar Duraikannan on Disruptive Engineering on the 24th of September. Following that Ts. Harvin Kaur Gurchran Singh had her talk on Emulsion on the 2nd of October and was in collaboration with the student section of Society of Petroleum Engineers (SPE) of APU. Lastly Mr Syed Mohd Bahrin had a talk on Vehicle Suspension System which was done in collaboration with UoSM IMechE SC.

Other talks such as the Smart Healthcare by Dr Roland Victor held on the 19th of October as well as the MATLAB workshop in collaboration with SPE on the 10th to the 12th of December were also conducted by the APU IMechE SC. In total the talks garnered about 100 participants and the talks are still available on the APU IMechE SC YouTube channel.



TECHTALK
IMechE APU Student Chapter

EMULSION

Saturday, 2nd October 2021
FB & YT live | 2.30 - 3.30PM

Ts. Harvin Kaur
Gurchran Singh

Come join us to learn more about Emulsion and how these temporarily stable mixtures behave in various phases !

Scan to access the live event Scan to register

APU MALAYSIA
STUDENT CHAPTER
Institution of
MECHANICAL
ENGINEERS

APU MALAYSIA
STUDENT CHAPTER

Institution of
**MECHANICAL
ENGINEERS**

Institution of Mechanical Engineers (IMechE)

INOTECH 2021

DR. ARUN SEERALAN
OCTOBER 2021

“InoTech 2021” is an event planned and organized by the IMechE APU Student Chapter in collaboration with the IEM APU Student Section, whose main demographic are innovative engineering students but is also open to all university students to join. The participants get the opportunity to exhibit their talents on various technologies whether in their relevant field of engineering or elsewhere to showcase to professional engineers hailing from various institutions. While also being a chance to show off their skills, the students compete as well to win a hefty sum. This competition is incorporated within Inotech 2021 to increase the motivation and willingness of students and to prepare them for the industrial difficulties of the industry. The purpose of the event is to sharpen the minds of the students by thinking with a goal in mind speaking persuasively while exploring their ability to solve technical problems creatively and sustainably.

The event was conducted fully online via MS Teams on the 29th of October 2021 with the support of the Institute of Engineers, Malaysia (IEM) through their IEM Excomm who annually supports a design competition within local universities. IEM’s contributions were to make available judges for the Inotech Design Competition, promote the event within the IEM circle of publications/magazines/bulletins and endorse APU as a partner in design innovation for the development of Science, Technology, Engineering and Mathematics (STEM) education in Malaysia. Dyson also provided their support for the event by sending us some representatives as judges for the competition. They also conducted a talk prior to the event.

A total of 42 projects were submitted for the event, each showcasing very impressive innovations to our guest judges. Our judges this year were Ts Ir Dr Lohgheswary Nagarethinam, Assoc. Prof. Ir. Jeevan Kanesan, Ir. Ts. Dr. Baljit Singh A/L Bhathal Singh, Ts. Dr. Vimal Rau Aparow, Dr. Zulhasni Bin Abdul Rahim, Mr. Affendi Zamzam, Ms. Eilenne Loh, Ms. Aida Zamnah and Ts. Dr. Vinothini Kasinathan.

After careful deliberation from the 9 judges the winners for the Inotech 2021 were announced during the award ceremony. The first prize winner was Chin Wei Chung with the project ‘A Single Phase Buck-Boost based Common-Ground Transformerless Inverter’. In second place was Abdulmajeed Hamad Abdullah Bin Shahbal with the project ‘Simulation of polymer alternating Gas (PAG) flooding In a synthetic Highly permeable reservoir model’. The third prize winner was Lorenz Kent Concepcion with the project ‘Street Wind-Turbine Power Generation System’. Additionally, Ho Tian Siang stood at 4th place with his project ‘Development Of AR Control And Monitoring For Smart Manufacturing Plant With Iot Interface’ and Wong Wei Syuen with the project ‘Online Exam Video Proctoring System’ at 5th place.

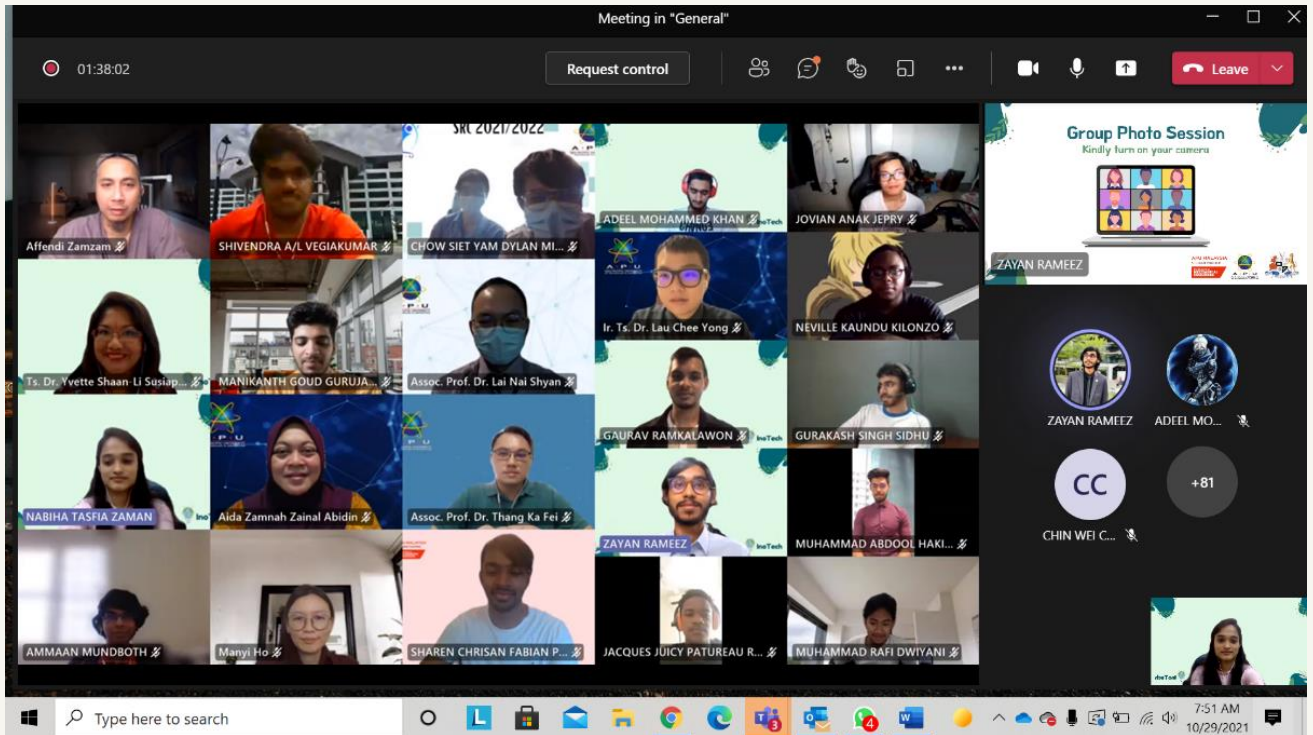

A picture of the attendees for the awards ceremony

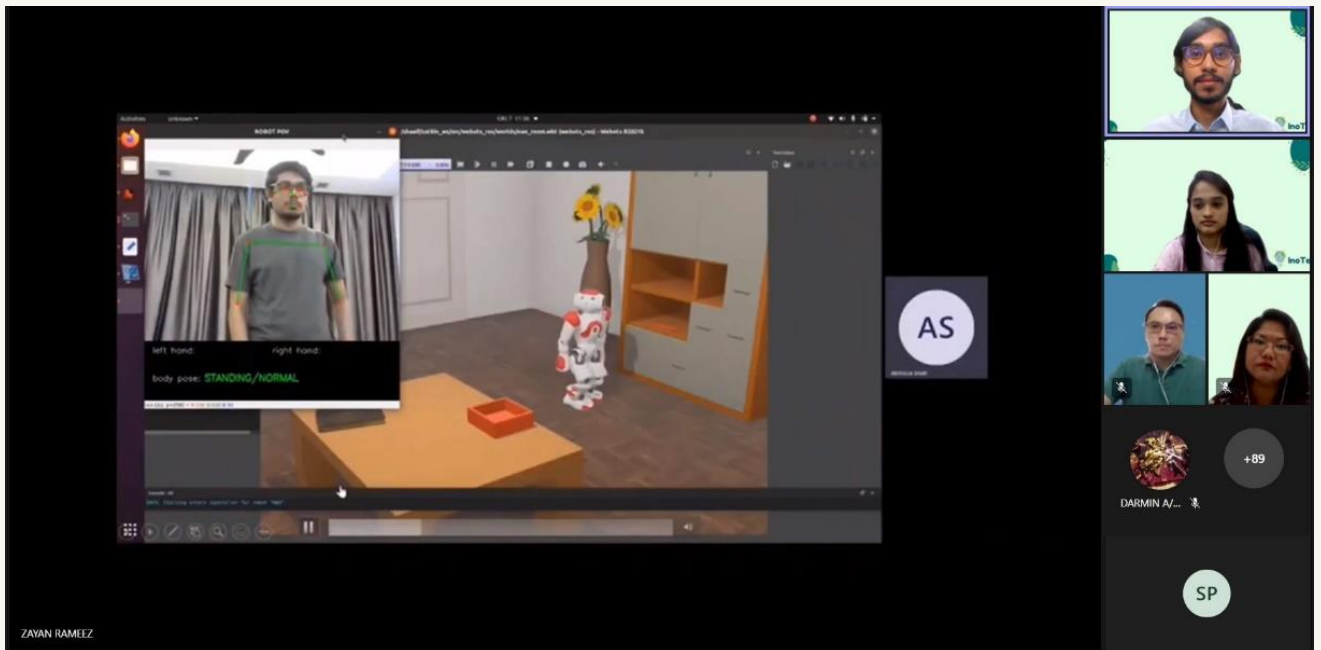

One of the projects submitted to the Competition

APU MALAYSIA
STUDENT CHAPTER

Institution of
**MECHANICAL
ENGINEERS**

Institution of Mechanical Engineers (IMechE)

DESIGN SKILL COMPETITION 2021

DR. ARUN SEERALAN
NOVEMBER 2021

Asia Pacific University IMechE Student Chapters was honored to collaborate this year's Design Skill Competition 2021, with IMechE Young Members Section Malaysia and Monash University Malaysia IMechE Student Chapter. The Design Skill Competition 2021 was virtually organized on November 27, 2021.

The main aim of the competition was to cultivate the student's ability to work in teams, use their creativity and analytical skills to invent, design and turn ideas into products build based on various criteria provided, among young engineers. And the core objective of this Design Skill Competition is to provide the young engineers from different Universities across the nation to experience, learn and cultivate their skills in 3D modelling and designing, by using SolidWorks as their design software.

This 3D designing knowledge especially with the aid of SolidWorks software is a crucial tool looked forward to and appreciated in most engineering-based companies and institutions especially in today's virtual world. With that in mind, this Design Skill Competition, which was held fully online via MS Teams, welcomed all degree seeking IMechE Student Affiliates to use this challenge as a stepping-stone to bolster their future career as an engineer on a professional aspect while enabling them to exchange tips and tricks on how to design faster maintaining industrial standards and accuracy. Nine teams consisting of two members from six different Universities competed this year.

At the end of the elaboration on the rules and regulations as well as the procedures of the competition to the participants, the teams were provided with the topic of the design as the competition commenced. All teams were required to begin with the hand sketching of design based on the topic given, that is to design a robot that can assist in farming lands and fields of wheat. The robot's design had to be capable of completing the project's requirements. Once sketches were completed, the teams were given a duration to submit their final design and model respectively. The teams final design submissions displayed exceptional creativity and professionalism abided by the criteria provided.



A picture of the participants and judges

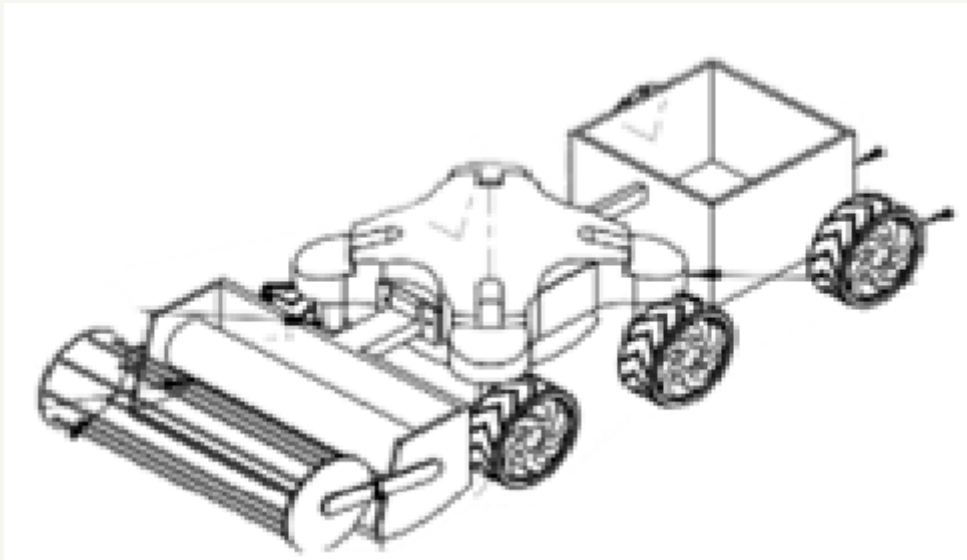

One of the designs submitted by students

APU MALAYSIA
STUDENT CHAPTER

Institution of
**MECHANICAL
ENGINEERS**

Institution of Mechanical Engineers (IMechE)

HANDOVER CEREMONY 2021/2022

DR. ARUN SEERALAN
NOVEMBER 2021

The handover ceremony was a celebration held by the APU IMechE Student chapter. It was held on the 23rd of November and was hosted in a hybrid mode meaning both online and physically. The ceremony has held to thank the previous committee for their hard work by awarding them with their certificate of recognition and also to introduce the new committee of the new term formally. There were various lecturers invited to the ceremony as well and the after the ceremony was concluded a small tea party was also held.



A picture taken at the ceremony

Society of Petroleum Engineers (SPE 2021)

Annual Technical and Exhibition Conference (ATCE) in Dubai, UAE



Asia Pacific University
SPE Student Chapter

SPE SEPTEMBER 2021

This year the SPE Asia Pacific University Student Chapter (SPE APU SC) was represented for the first time in the SPE Annual Technical and Exhibition Conference (ATCE) in Dubai, UAE by Abdallah El Badaoui who currently serves as its President. Abdallah is a final year Petroleum Engineering Student; he was named as one of the 8 Energy Leaders for Tomorrow in 2020 by Energy Intelligence and just completed his internship with Total Energies in Tanzania. He was one of the founding committee members of the chapter and took over from the founding president Syed Qadri last year to continue serving their SPE members.

On 21st to the 23rd September took place at the Dubai World Trade Center, in the UAE, the Annual Technical Conference and Exhibition (ATCE) of the Society of Petroleum Engineers (SPE). This is the annual gathering of SPE members and oil and gas passionate, bringing together technical experts across the energy industry.



SPE APU SC President 2021

They come together not only to celebrate the achievement of the past year, but to share knowledge and experiences. It gives the opportunity to present, discuss and publish papers while providing a platform for networking and discussing the future of the industry.

It was the first time since the pandemic that the conference was held physically, coming back stronger in a hybrid format, allowing members and participants from all over the world to take part in this global gathering.

This conference is considered as one of the biggest and largest rendezvous of oil and gas enthusiasts and energy professionals. Founded in 1924, the conference will soon celebrate its centenary, bringing together 6000+ professionals, more than 400 technical presentations, 80+ conference sessions and 70 exhibitors showcasing the latest technologies in the industry. This year's gathering was even more special as it was organized in conjunction with GasTech, the largest convention on gas in the world, regrouping 35 000+ delegates, more than 1000 exhibitors, 1000+ ministers and C-level executives, 3 500 attendees and more than 300 speakers.

What is the energy transition and is it a shift from one source to another?

ATCE being held in a time where the world is recovering from two years of Covid19 Pandemic, the main topic of discussion was addressing how are we moving forward as an industry. The world is pressurized to balance between the call for climate action and meeting the global energy demand. The energy transition is a reality that we have to face and probably the biggest challenge of the 21st century. It is agreed by many that oil and gas is here to stay for at least 50 years from today, oil and gas constitute about 56% of the energy mix and will continue to constitute a big part of the energy demand in the future. The rise of renewable energy technologies and their affordability is very promising for the industry, but they cannot totally replace oil and gas in the upcoming decades to say the least. Gas will in contrast play a big role in the energy transition, with lower carbon emissions than oil, it presents a short-term alternative while we continue battling climate change and developing better, cleaner and affordable sources for all. Many countries and oil and gas companies have expressed their ambition to become Net zero by 2050, what does “net zero” really mean?

Net zero doesn't mean that we will not produce oil and gas or that we will not emit CO₂, but on a positive note it means that we will manage the carbon that we will be emitting, so that the carbon emitted is equal to the carbon removed. One may ask, how are we going to remove the carbon? Well, it is a step-by-step process, and our experts are still searching and developing the best way possible to do so.

To reach net zero, few things are very much essential:

- **Gas development** – to decrease already the carbon being emitted while continuing meeting the growing energy demand.
- **Energy efficiency** – make sure that we optimize our usage and decrease wastes
- **Renewable energy development** – this will be one of the drivers of the energy transition to provide clean and reliable energy (Geothermal, solar, wind, etc...)
- **Carbon Capture Utilization and storage (CCUS)** – a technology which consists of capturing the carbon in the atmosphere and keeping it in depleted reservoirs and porous formations, this will decrease the carbon in the atmosphere, hence global warming.
- **Hydrogen** – this is one of the emerging technologies in the energy transition, three types of hydrogen shown below. (Source: bp's CEO on LinkedIn).

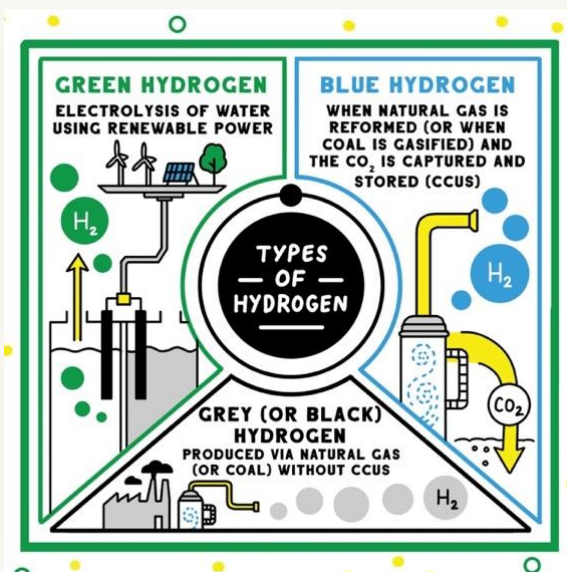

We cannot talk about energy transition without talking about the role of governments, corporates, NGOs and similar organizations. How can we increase accountability, create incentives for change and make sure that all efforts don't go in vain? Some of the promising discussions around the energy transition and its policies is on carbon taxation, what does this really mean? Under a carbon tax, the government sets a price that emitters must pay for each ton of greenhouse gas emissions they emit. Businesses and consumers will take steps, such as switching fuels or adopting new technologies, to reduce their emissions to avoid paying the tax. ('Carbon Tax Basics', 2021). On the other hand, there is carbon credits, which is defined to be "the right to emit a measured amount of Green House Gas (GHG). Carbon credits work as a certification that business or individual owning them is counterbalancing the emission of greenhouse gases". ('What Is Carbon Pricing And Carbon Credit? Definition, Countries, Trends', no date). Carbon taxation and credit will play a crucial role in this era of the energy transition, especially in the battle of climate change, it will attempt to make visible the social costs of carbon emissions.

What's the way forward?

The energy industry is known to be an uncertain one, governed by a lot of factors, but what's clear from the industry point of view is that we want to be part of the solution. There are no better people having a better expertise, network, funds and men power to drive the energy transition than the people in the oil and gas industry. We have been part of the energy business for years and we will be part of it for another good amount of time. So, what should be our contribution and the key factors to address?

Key factors for the transition:

- Capital to invest in research and development, but also to invest in new projects and ventures.
- Partnership between all sides of the industry, from corporations to governments and NGOs, within our disciplines but also cross disciplines including renewable experts.
- Attract and retain talent in the industry so that we can push on research and innovation .
- Innovation that can only be brought by new talents and freshers in the industry.

As a Petroleum engineer or someone studying oil and gas related field, what can I do now? And how do I prepare for the transition?

It is also very clear that technology will be a focal point in the energy transition. According to an expert, what we as students are going through right now has happened in the past. The pressure that the world is shifting to alternate energies and that petroleum engineers will not be any more in need is not new. But according to that expert, there will be shortage of petroleum engineers in the next 5-10 years, due to the existing pressure, more student will venture towards other field, and when there will be shortage of petroleum engineers, again we will encourage people to study it and its related fields.

The skills of petroleum engineers will be much needed in the realm of the renewable energies, be it geothermal where we will use our understanding of the earth and its component to generate energy, be it CCUS, where we will use our vast knowledge in extracting oil and gas to do the reverse and inject CO₂ or again utilize our expertise to venture in R&D for the type of hydrogen that could generate energy. The the main one remains how we will continue to produce gas from our respective reservoirs to continue sustain the growing energy demand.

All or most of the skills needed for the energy transition are already the core subjects of petroleum engineers, so we should not fear but instead be proud of being part of this industry which runs the world, powers the development of our nations, scientific and technological advancement and drives us around to enjoy our cultures and celebrate our diversities.

We should start polishing our skills and add value to our petroleum degrees, either by studying the emerging technologies, such as data science, AI, big data etc... or draw interest in the new ways of producing energy, so that combined with our core skills, we can become valuable, flexible and help the world in the energy transition.

Apart from the Technical sessions, what does ATCE entails?

ATCE is known for being the annual conference for SPE members and Oil and Gas professionals, not only because of the sharing of expertise that happens but also the opportunity that it comes with to network with the most experienced professionals in the industry.

In this global gathering, I got the chance to meet Mr Tom Blasingame, 2021 SPE President and Mr Kamel Bennaceur, 2022 SPE President who both were keynote speakers for the opening and closing ceremony of Saturday is for SPE 3.0 (S4SPE 3.0) respectively, the flagship event of the SPE APU SC. I got to network with fellow student officers coming from different universities but also finally meet face to face some of my LinkedIn connections.



With Prof Tom Blasingame 2021 SPE President



Receiving the Excellence award from SPE international

It was my honor to receive the Student Chapter Excellence award of the SPE APU SC, an award which recognizes the top 20% chapters around the world. This is the first award of the chapter but also the first collective award of the petroleum department at APU, following the Energy leader for Tomorrow last year. The Student Excellence award is even more special to our chapter and our officers, considering the chapter was established in the middle of the pandemic in 2020, receiving an award in the first year of operation just portrays how much hard work and dedication is kept by the student officers, trying our best to advance the SPE mission in our university.

Finally, as a young professional, I got the chance to be invited to the networking night post-conference, courtesy of the SPE North Emirates Section, which has good ties with SPE APU SC. It was a great opportunity to learn from those who just entered the industry, make long lasting friendships, and discuss how to inspire and serve our generation of leaders. The networking session was a great time, where I got the chance to interact with the Young Member Engagement Committee incoming chair Nihal Mounir, whom we worked together virtually for S4SPE 3.0.

ATCE is a special time and a rewarding experience, I recognize the impact it will have on the long run in my career, and I encourage my fellow students to be active in SPE so to get the opportunity one day to attend as a student before attending as a professional. Remember: “your network is your net worth”.

I would like to express my gratitude to Asia Pacific University especially the School of Engineering for facilitating my trip and for sponsoring my attendance to the conference.



President Luncheon - Prof Tom Blasingame outgoing president yielding the presidency officially to Prof Kamel Bennaceur, incoming president



With Mr Kamel Bennaceur SPE 2022 President



Abdallah with SPE North Emirates Chairperson Oumer Tahir and Mohamed Al Balushi, reservoir engineer at bp, petroworld finalist, 2x SPEChapter President and fellow energy leader for tomorrow 2018

Society of Petroleum Engineers (SPE 2021)



Asia Pacific University
SPE Student Chapter

SPE DECEMBER 2021

The flood relief collaboration aimed to assist the thousands of people who were affected by the heavy rain that caused flood in the country, the heavy rain has displaced families and communities making the situation an emergency promoting the two APU communities to act immediately. The flood relief fundraising was first started on 22nd December 2021 and the donations received till Friday 24th December 2021.

The donations were aimed to buy medical supplies, hygiene supplies, food assistance, clothes and any other items that could help with the situation. On the 26th of December the goal was to buy the emergency items including, hygiene supplies and food such as rice and cooking oil. The items were then packed with the clothes ready for distribution the next day. After the necessary items have been bought, the team arranged to take part in assisting the food bank in Gurdwara Sahib Petaling Jaya on the 27th of December.

FUNDRAISING FOR FLOOD VICTIMS BY THE SPE APU AND ASAPU COMMUNITY

When flood waters rise, we rise up as a
COMMUNITY.



FLOOD RELIEF EMERGENCY FUNDRAISING

Join us to support the people impacted by the recent flash flood by making a donation.

We are collecting clothes for the flood victims. We also accept other donations for good.

Drop off location: APU campus
PIC: Noor (+60166438162)

Make donation now to

MAYBANK: 112893121636
(AHMED KHALED HASSAN)
REF: Flood Relief

For receipt & further inquiries or to volunteer:

+60177651772 (Geerba)

Open till: Friday, 24th Dec 2021



The team took part in providing manpower in Gurdwara with the supervision of miss Harvin Kaur who is the advisor of the SPE APU. The assistance provided by the team included:

- Help packaging and loading items for the delivery
- Unpacking and unloading newly brought items
- Assisting with keeping track of number of items being loaded into the trucks

The results of the flood have been devastating and a tough situation for many, that's why we most come together and provide help for those in need, the SPE APU and the ASAPU community will come together to achieve that goal.

SPE APU and the APU African society would like to thank all the generous donors, especially APU students and staff who have shown support towards this cause.

Special thanks to the APU management for arranging for the transport, both for the volunteers and the goods so that they could be delivered in good hands.

Finally, a great thank you for all the volunteers involved, without whom, this event would not have been a success.

