

ENGINEERS INSIGHT

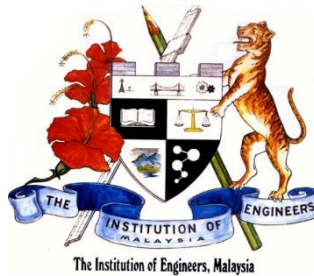

A . P . U
ASIA PACIFIC UNIVERSITY
OF TECHNOLOGY & INNOVATION



A . P . I . I . T
ASIA PACIFIC INSTITUTE
OF INFORMATION TECHNOLOGY

SCHOOL OF ENGINEERING

JANUARY 2016

VOLUME 13



Memorandum of Agreement (MoA)
with Signal Transmission (M) Sdn Bhd

Lead Editor

Shankar Duraikannan

Editorial Team

Prof Dr Ir Vinesh Thiruchelvam

Contributors

Dr.Thang Ka Fei

Dr Raed Abdulla

Dr Sathish Kumar Selva Perumal

Ms.Vickneswari A/P Durairajah

Mr Kudzai Nigel Chitewo

In this volume

- Welcome Back
- Artificial Photosynthesis for Cleaner Fuel
- IEM Seminars & Workshops
- IEM Industrial Visits
- SoE Competitions
- SoE Collaborations
- SoE Conferences
- SoE Final Year Projects
- SoE Articles
- SoE Events

If you would like to be a part of the 'Engineers Insight' editorial team or have an article / paper published please contact: shankar@apu.edu.my

Engineers Insight' is a quarterly issue by the School of Engineering for the reading pleasure of the staff and students allowing for knowledge sharing and capturing of events for the benefit of engineering education.

Welcome Back!

Happy New Year 2016 and welcome back to APU! The New Year is always a great time for us to reflect on past happenings and to make promises for change, i.e. the New Year resolution. Quite often, we are excellent at making new vows to change or to improve, but the resolution may not be realistic or achievable. This is because we may not have reflected on past mistakes or reviewed on past outcomes when making new promises to change. It is important that we learn from the past in order to plan for the future and to ensure that we are able to make progressive improvement to our life and to the lives of people around us.

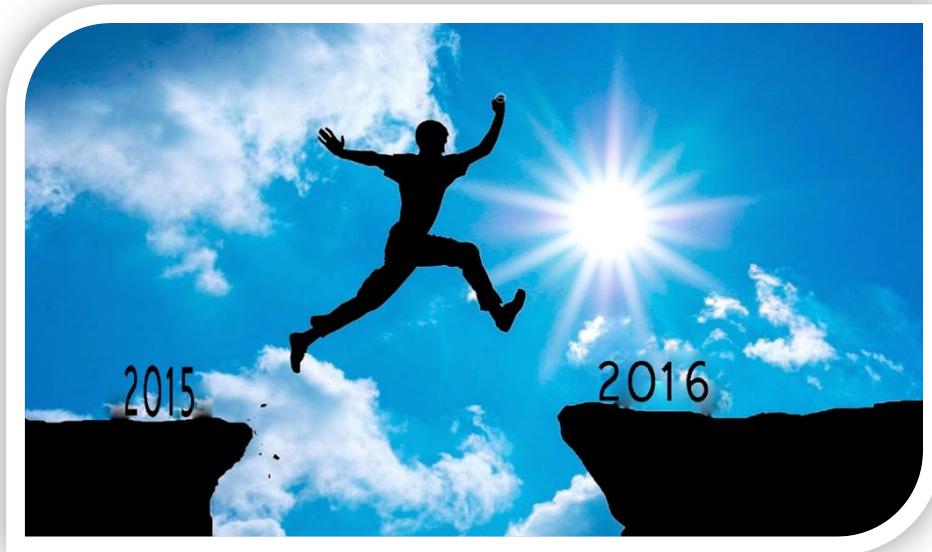

For those of you that have made a resolution list for 2016, I would be glad to hear from you on what they are, do drop me an email! And for those who have not decided on what those resolutions are, I would like to offer a few suggestions that you may want to add to your list.

Be a Go-Getter. A go-getter is a person that is energetic, determined to be successful and able to cope with new or difficult situations. Let's reflect on what had happened in 2015; how often have you delayed starting on your assignment till the very last moment? And, how often were you absent from your peer discussion on group work? A go-getter person will be self-initiated and proactive in everything they do and typically they will also obtain good grades in their study. You can vow to be a go-getter in 2016!

Be a Good Time Manager. Typical University students' life is bustling with studies and leisure activities. It is quite easy to loose focus and be lopsided with either leisure or studies and hence not beneficial for your personal development. An enjoyable University experience should evolve around a balanced diet of both, which involves no other than good management of your available time. For 2016, my suggestion is for you to list down all activities, starting from weekly to monthly, and start assigning priorities to them.

Try something new! Looking back at 2015, have you joined any industrial visits organised by the IEM-APU Student Section (IASS)? How often have you participated in talks, workshops or competitions either in the University or externally? If you have not, 2016 will be the year where you will vow to make a change! Activities that have been highlighted are beneficial for your exposure to real-word engineering.

Connect and Engage. If you have not been seeking consultation from lecturers in 2015, now there are plenty of opportunities to do so in 2016. Having to connect with your lecturers and engage in consultation in and out of lectures are vital for your success in class-tests, assignments and final exams. In addition, you should connect with classmates and actively engage in group discussions; you will soon discover that this helps in completing your assignments and design work activities much faster and with better quality to that of doing it alone!

In summary, you have made a commitment to improve as long as a resolution is made; If you have not made any resolution do consider the suggestions above. All the best in 2016!

ARTIFICIAL PHOTOSYNTHESIS FOR CLEANER FUEL

Let us first recall the natural manner of photosynthesis, which is the process by which green plants use sunlight to synthesize foods from carbon dioxide and water. The process combines 6 molecules of carbon dioxide and 6 molecules of water to produce one molecule of glucose and 6 oxygen molecules. The glucose is stored in the plant as starch and cellulose which are simply long chain glucose molecules (known as polysaccharides) as a source of food for the plant to survive and grow. The oxygen that is produced as a by-product of photosynthesis is what most animals rely on to breath, so this process that plants and trees fulfil is critical to our survival.

So what's artificial photosynthesis? It basically works with the 'artificial leaf', where sunlight is converted directly into solar fuel, without making use of biomass as in the production of biofuels from plants, and without involving an electricity network, as in electrolysis using power from photovoltaic cells.

It is a chemical process that imitates natural photosynthesis at the molecular level. Sunlight is used to convert water and CO₂ into oxygen and hydrocarbons or hydrogen (Figure 1). Because of its high efficiency, artificial photosynthesis has the potential to provide an alternative to fossil fuels.

What could the production and use of solar fuels look like?

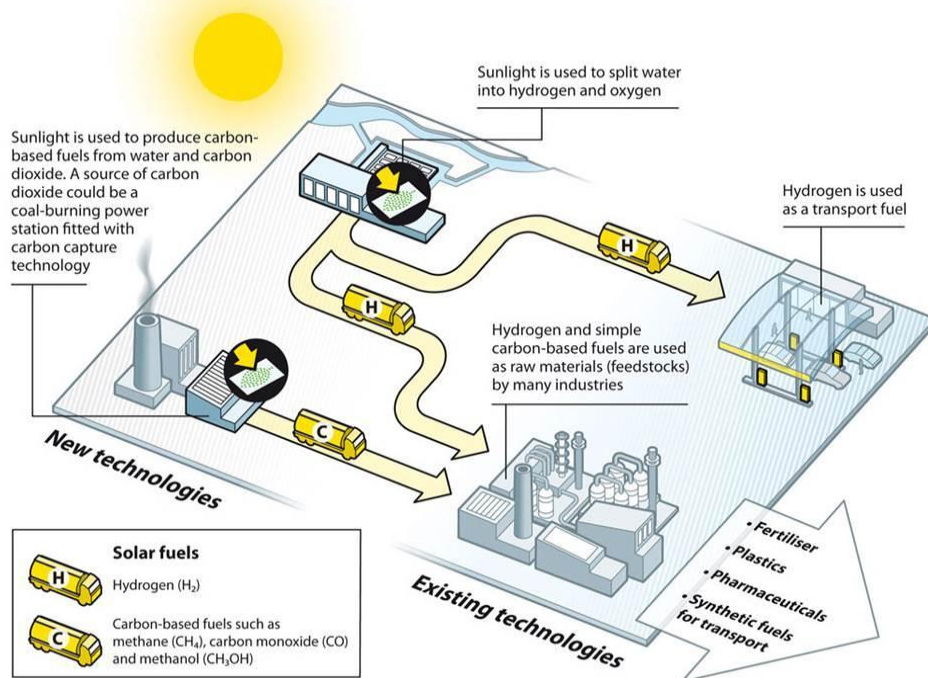

© Royal Society of Chemistry

Figure 1: The production of solar fuels.
(Source: Royal Society of Chemistry)

An Artificial photosynthesis involves four stages, making it very similar to the natural photosynthesis process:

Light harvesting: The collection of light particles (photons) by antenna molecules and the concentration of the collected energy in a reaction centre.

Charge separation: At the reaction centre, the collected sunlight is used to separate positive ('holes') and negative (electrons) charges from each other.

Water splitting: Positive charges are directly injected into catalytic centres where they are used to split water into hydrogen ions (protons) and oxygen.

Fuel production: Electrons from step 2 are given more energy from new photons and subsequently combined with the hydrogen ions and possibly CO_2 to produce either hydrogen or a carbon-based fuel

The **carbon-based fuels** that may be produced by means of artificial photosynthesis are not complex molecules like carbohydrates, but simpler molecules such as methane, methanol and carbon monoxide. The processes by which these fuels are produced are more complex than those involved in the production of hydrogen, because in many cases more than four electrons and protons and more than eight photons play a role in the reaction. The storage of energy in carbon-based fuels represent a major scientific challenge. However, carbon-based fuels have the advantage that most are of liquid form and could therefore be integrated into the existing energy infrastructure relatively easily.

Producing hydrogen by splitting water using sunlight

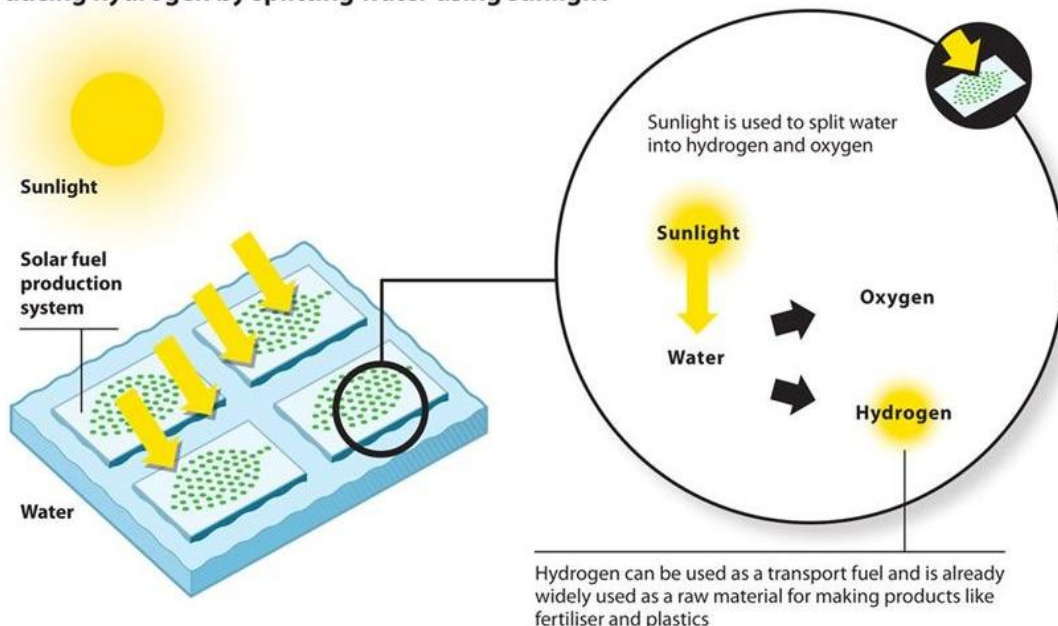

© Royal Society of Chemistry

Figure 2: Producing hydrogen by splitting water using sunlight.
(Source: Royal Society of Chemistry.)

The most famous and an excellent example is the Panasonic's artificial photosynthesis system which has a simple structure with a high efficient CO_2 conversion, which can utilize direct sunlight or focused light.

Panasonic found that a nitride semiconductor has the capability to excite the electrons with enough high energy for the CO_2 reduction reaction. Nitride semiconductors have attracted attention for their potential applications in highly efficient optical and power devices for energy saving. However, its potential was revealed to extend beyond solid devices; more specifically, it can be used as a photo-electrode for CO_2 reduction. Making a device structure through the thin film process for semiconductors has improved the performance as a photo-electrode.

The CO_2 reduction takes place on a metal catalyst at the opposite side of nitride semiconductor photo-electrode as shown in Figure 3. The metal catalyst plays an important role in selecting and accelerating the reaction. Here, it is noted that the system comprises of only inorganic materials, which can reduce the CO_2 with low energy losses. Because of this, the amount of reaction produced is exactly proportional to the light power. This is one of the merits in such an all-inorganic system while some conventional systems cannot follow the light power in general because of their internal or external rate-limiting processes in the complex structures.

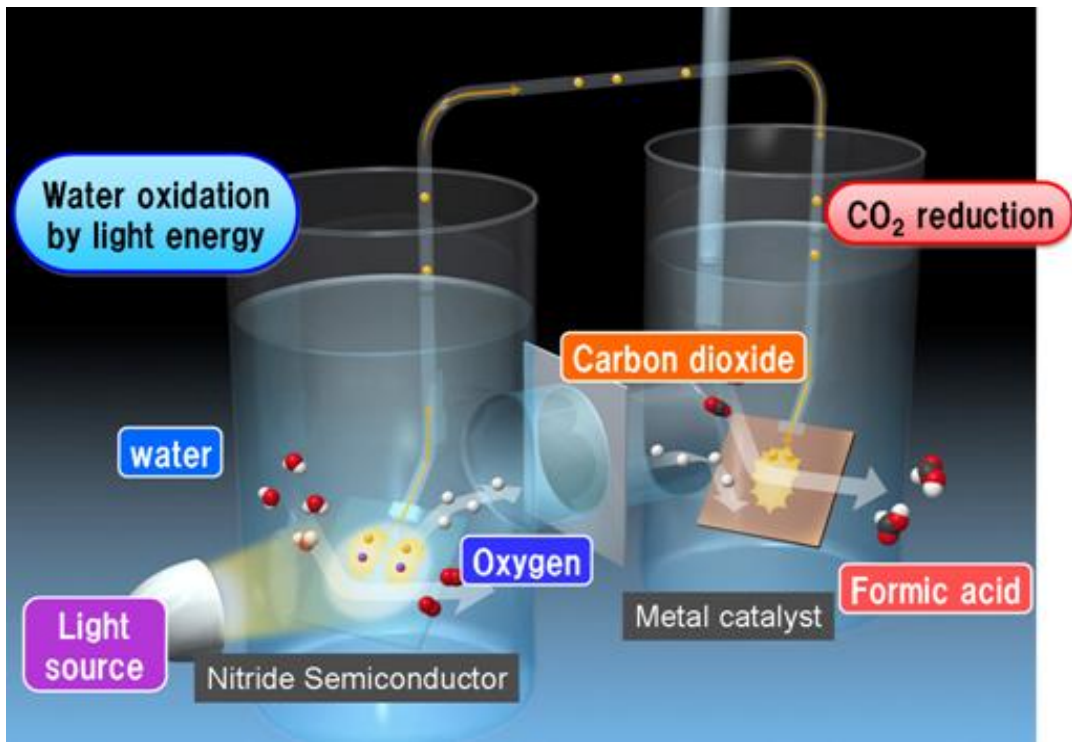

Figure 3: Schematic view of artificial photosynthesis system
 (Source: news.panasonic.com/press/news/)

The system with a nitride semiconductor and a metal catalyst generates mainly formic acid from CO₂ and water with light at a world's top efficiency of 0.2%. The efficiency is of a comparable level to real plants used in the biomass energy source. The formic acid is an important chemical in industry for dye and fragrances. The reaction rate is completely proportional to the light power due to the low energy losses with simple structure; in other words, the system can respond to focused light. This will make it possible to realize a simple and compact system for capturing and converting wasted carbon dioxide from incinerators and power generation plants.

However this development of artificial photosynthesis is still in a testing and laboratory phase. Much remains to be accomplished before commercial application is possible. Nevertheless, artificial photosynthesis has the potential to be an attractive and sustainable alternative to fossil fuels. Furthermore, artificial photosynthesis can contribute to transformation of the energy infrastructure as a whole.

For a better understanding watch a sample video “Artificial Photosynthesis, an Energy Technology of the Future” on YouTube.

References

FAO, How to feed the world in 2050, 2009, FAO.

International energy agency, World energy outlook, 2011, International energy agency.

Cogdell, R.J., et al., Artificial photosynthesis – solar fuels: current status and future prospects. *Biofuels*, 2010. 1(6): p. 861-876.

Ball, P. Reinventing the leaf. *Nature News* 1999; Available from: <http://www.nature.com/news/1999/991004/full/news991007-3.html>.

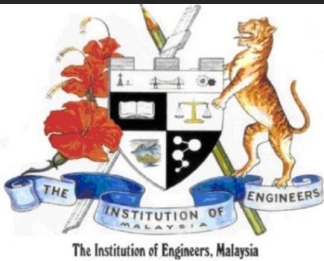

SEMINARS & WORKSHOPS

FUTURE CAREERS IN APPLIED SCIENCES



An invited talk on 'Future Careers in Applied Sciences' by Prof. Dr. Chandima Gomes, University Putra Malaysia, was held on October 7, 2015. The talk was focused to the current trends, demands and career opportunities in key areas of applied sciences. 45 students 15 staff attended the talk.



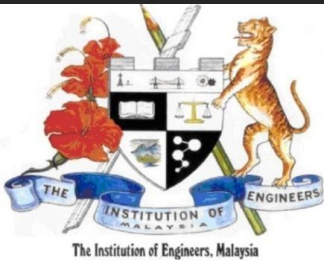

SEMINARS & WORKSHOPS

SUSTAINABILITY CONCEPTUALIZED



An invited talk on 'Sustainability Conceptualized' by Mr Alvin Long, ATechnologies Sdn Bhd, was held on October 7, 2015. The talk was focused to understanding sustainability from an architectural perspective. 35 students 15 staff attended the talk.



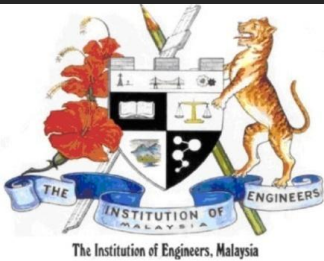

SEMINARS & WORKSHOPS

FUTURE CAREERS IN APPLIED SCIENCES



On October 9, 2015 Ir Wong Choong Onn of Technip Malaysia shared his experience in Professional Engineering Careers in the Oil & Gas industry. Ir. Wong is also the Industrial Advisory Panel Member of School of Engineering. 65 students and 5 staff attended the talk.



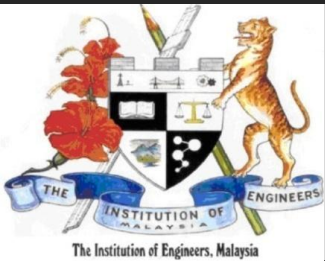

SEMINARS & WORKSHOPS

HISTORY OF MALAYSIAN SUBMARINE CABLE NETWORKS



An invited talk on 'History of Malaysian Submarine Cable Networks' by Ir Zulkeflee Bin Khalidin was conducted on October 16, 2015 exclusively for Telecommunication engineer. Ir Zulkeflee is the industrial advisory panel member of telecommunication engineering programme elaborated in detail the history of Malaysian cable networks and the technology, planning and deployment of submarine fiber optic networks. 35 students and 5 staff attended the talk.



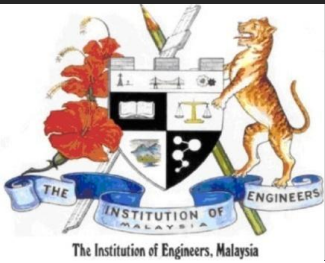

SEMINARS & WORKSHOPS

ICACCT – 2015 PRECONFERENCE WORKSHOP



A One Day Preconference Workshop on 'Numerical Methods from Complex Engineering Problem Solving Perspective Using MATLAB' was conducted by Mr Shankar Duraikannan at the 9th International Conference on Advanced Computing and Communication Technologies at APIIT, Panipat India on November 27, 2015. 30 students attended the workshop

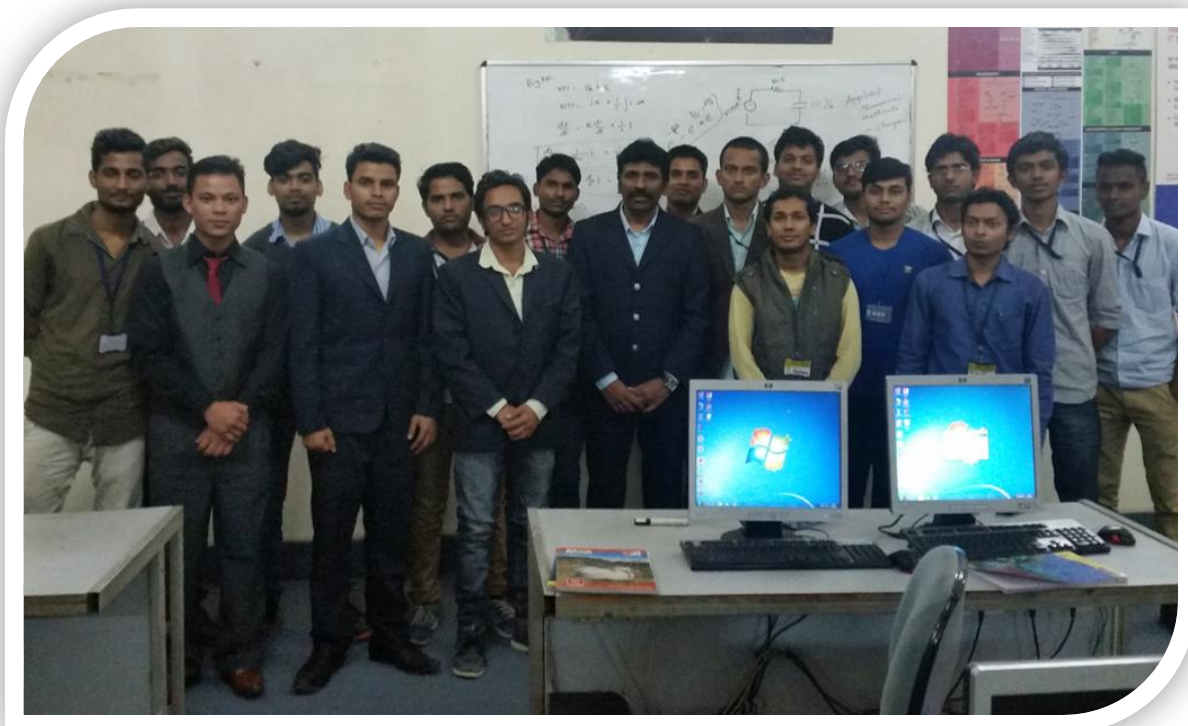

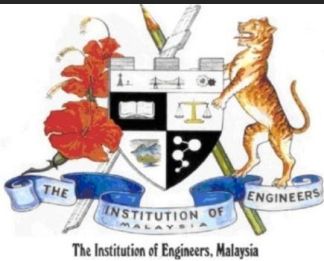

SEMINARS & WORKSHOPS

MATERIALIZE & ADDITIVE MANUFACTURING APPLICATIONS



An invited talk on 'Materialize & Additive Manufacturing Applications' by Mr Mahadi Mahmud representing Materialise, was conducted on October 19, 2015. The talk was on the three technologies of additive manufacturing applications such as Laminated Object Manufacturing, Laser Printing, and Stereo Lithography. 40 students and 3 staff attended the talk.

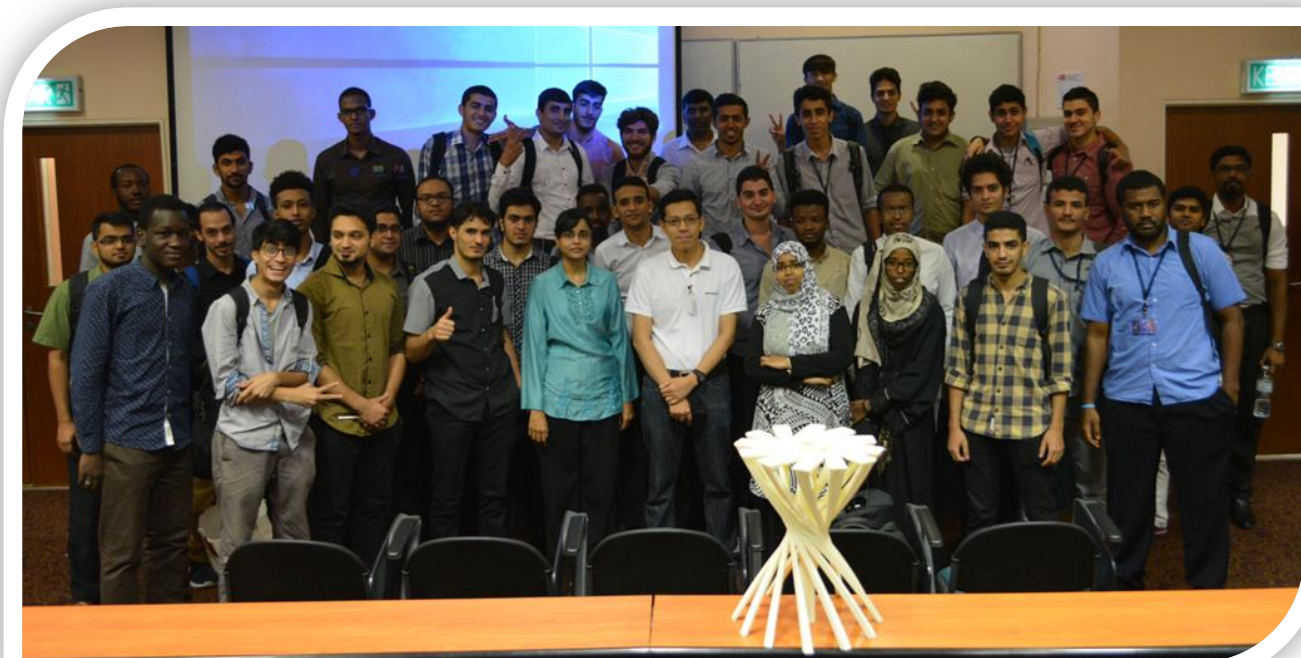

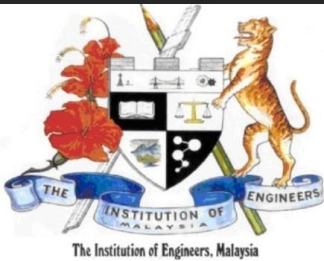

SEMINARS & WORKSHOPS

CREATIVE INNOVATIVE AND INVENTIVE TALK

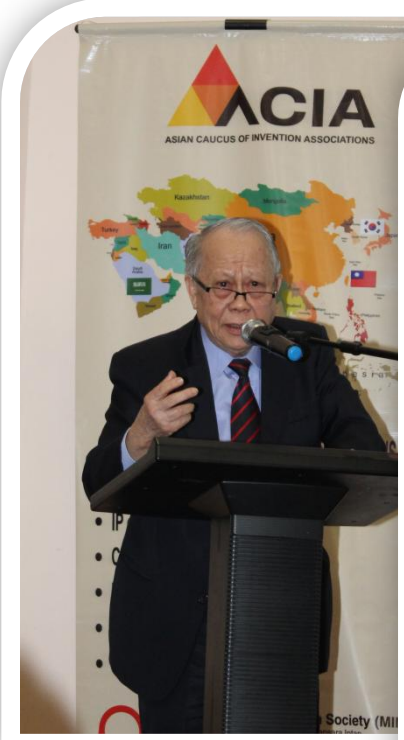

The 'Creative, Innovative and Inventive' talk organized on November 20 2015, by School of Engineering APU was an initiative session on networking students and industrial expert. Tan Sri Augustine Ong was humble enough to deliver a talk on 'An Introduction to Minds – Malaysian Invention and Design Society'. Several technical talks were presented by industrial experts and staff members of school of engineering which was well received by 150 student and 25 staff.

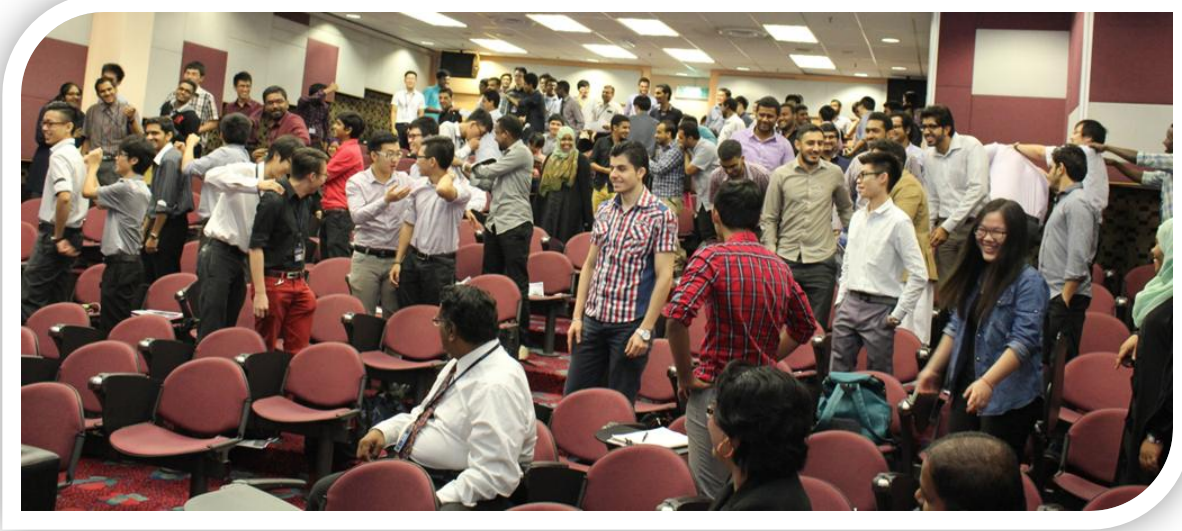

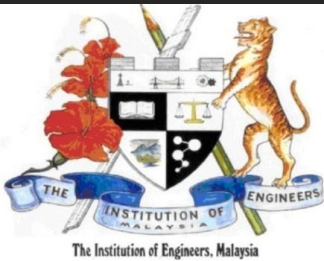

SEMINARS & WORKSHOPS

RASPBERRY PI JAM

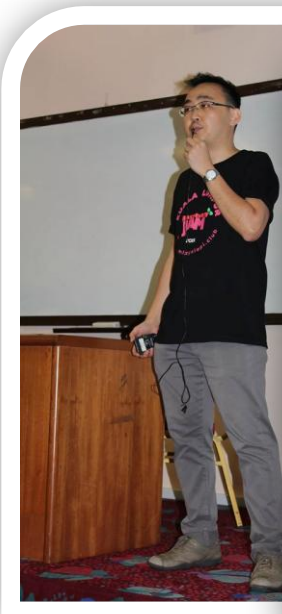

Raspberry Pi Jam Seminar/Workshop is the first of its kind technical workshop that was conducted on December 5, 2015 by experts of Raspberry Pi implementation and Python Programming. The workshop attracted and brought together to an audience of 250 which includes student staff and industrial personnel

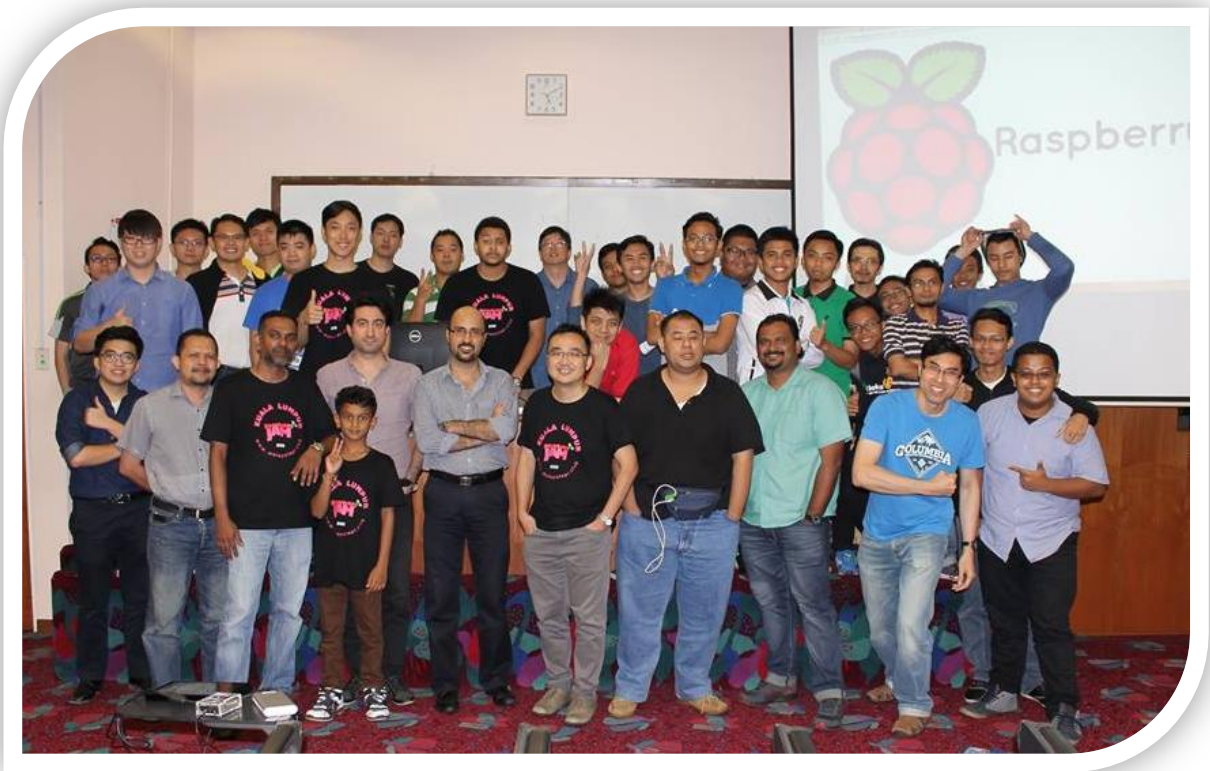

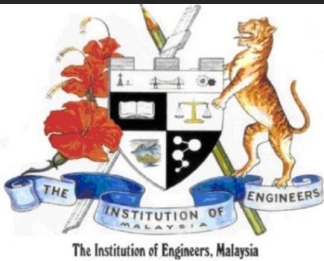

SEMINARS & WORKSHOPS

WIRELESS TECHNOLOGY BEYOND WIFI

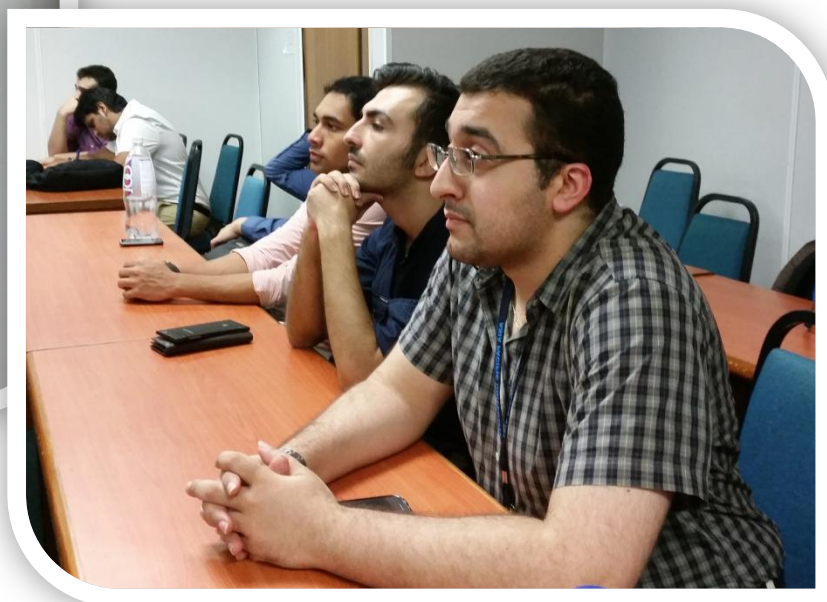

An invited talk on 'Wireless Technology Beyond Wifi' by Ir. Rohzan Abdul Rahman, Director, Ridaa Associates Sdn Bhd was conducted on December 10, 2015. Ir Rohzan is the Industry Advisory Panel member for the School of Engineering. The talk was exclusive for telecommunication engineering students focused to the recent trends, technologies and business of wireless technologies. 45 students and 5 staff attended the talk.



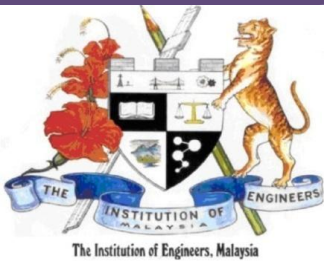

INDUSTRIAL VISITS

O.Y.L Manufacturing Company Sdn Bhd



OYL Manufacturing Company Sdn Bhd located in Sungai Buloh, is a leading air conditioner manufacturer in Malaysia. The types of air conditioners manufactured by the plant includes, ASCON, McQuay, Daikin and York. On October 22 2015, 46 students accompanied by 3 staff visited the plant.



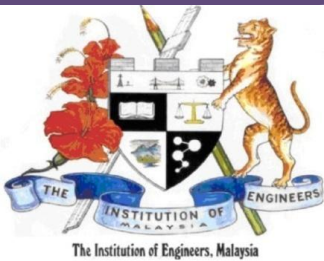

INDUSTRIAL VISITS

Vessel Bridge Simulator – National Defence University Malaysia



The Vessel Bridge Simulator is a realistic mock-up of a ship's bridge with all conventional controls and instruments which include manoeuvring and throttle controls, navigation instruments including GPS, LORAN and NAVTEX, an ARPA radar and ECDIS plotter. In addition, there is a realistic visual of the outside world. On October 22 2015, 17 students accompanied by 3 staff visited the Vessel Bridge Simulator facility at the National Defence University Malaysia in Sungai Besi.



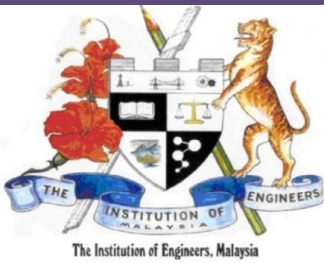

INDUSTRIAL VISITS

Clipsal Manufacturing Malaysia

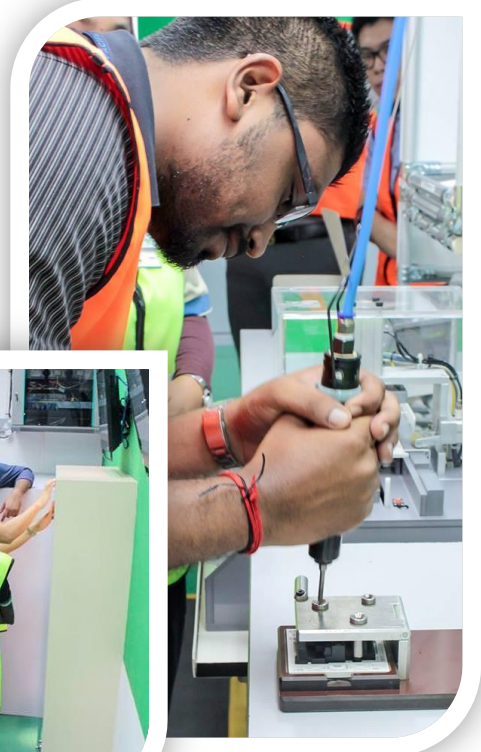

Established in 1977, Clipsal Manufacturing has brought to users top notch life space products around the world . Since joining the Schneider Electric family in 2004, it has expanded even more. On November 4 2015, 30 students accompanied by 2 staff visited Clipsal Manufacturing Malaysia. The visit provided the student with an hands on experience in switch manufacturing and assembling.





A . P . U
ASIA PACIFIC UNIVERSITY
OF TECHNOLOGY & INNOVATION
SCHOOL OF ENGINEERING

SOE COMPETITIONS

INOTECH - 2015

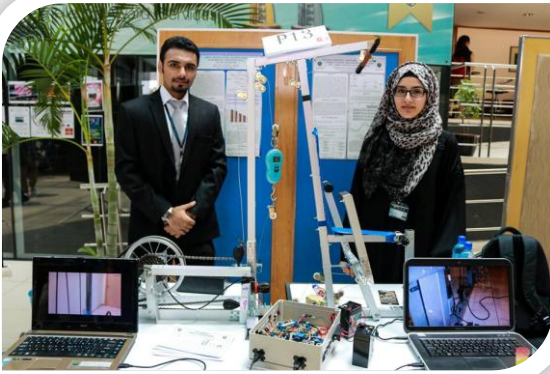

InoTech'15 an Innovation Exhibition Contest organized by SoE was held on October 8, 2015. There were 19 participants exhibiting their projects. The projects had a variety of unique ideas like Live Video Vision System, Paper Sorting System, Mechanical robotic hand and etc. Despite having stiff competition from their fellow competitors, Cleopatra Musa and Syed Abdullah impressed the judges with their innovative ideas and outstanding presentation. Thier project on integrated fitness with eco-friendly technology to produce the "Eco-Friendly Weight Lifting Machine" won the first prize. The competition was endorsed by the Institue of Engineers Malaysia (IEM).





A . P . U
ASIA PACIFIC UNIVERSITY
OF TECHNOLOGY & INNOVATION
SCHOOL OF ENGINEERING

SOE COLLABORATIONS

Memorandum of Agreement (MoA) with Signal Transmission (M) Sdn Bhd



An MoA was signed with Signal Transmission Sdn Bhd further to the good work put in the delivery of a industrial Final Year Project undertaken by our student Raja Ram. He was well guided by our lecturer mr Alvin Yap who not only developed Raja into a hands on engineer but also ensured he met time lines for the project. It was very supportive to see both lecturer and student who has graduated back in the same room for the signing process with Mr Tan from ST. The signing was done by Prof Ron Edwards on behalf of APU witnessed by the Dean and HoS.





A.P.U
ASIA PACIFIC UNIVERSITY
OF TECHNOLOGY & INNOVATION
SCHOOL OF ENGINEERING

SOE CONFERENCES

SoE @ IEEE SCORed 2015



Photos from the
SCORED
conference
events held in
Dec 2015.



A . P . U
ASIA PACIFIC UNIVERSITY
OF TECHNOLOGY & INNOVATION
SCHOOL OF ENGINEERING

SOE FINAL YEAR PROJECTS

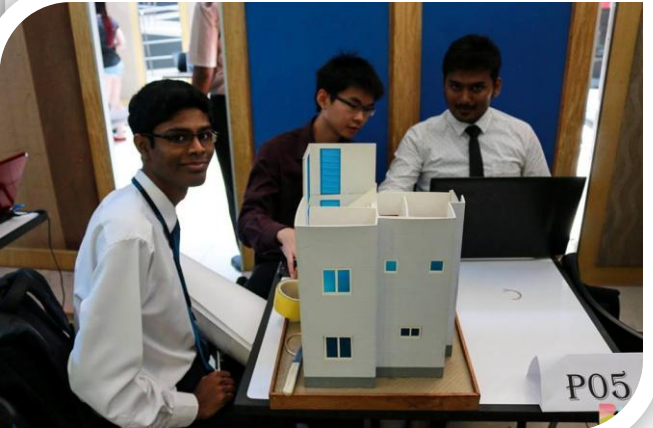

Final Year
Project
Presentation
UC4F1501

My APU Experience - Engineering and Beyond

Kudzai Nigel Chitewe

My eventful journey at APU began on the 15th of July 2011. It was my first time ever outside my home country. My experience at APU has been both scholastic and fascinating. I spent my Year 1 mostly focused on studies. However, from Year 2 to Year 4, I found myself balancing the pressures of engineering school work and extracurricular activities that sparked my interest.

The first club I joined due to my interest in science was the Maths and Science club which introduced me to a variety of people who have become lifelong friends. The second club I was fully invested in was the APU Wushu Club, and after 2 years in the club I got promoted to club President.



Figure 1: Wushu club post Merdaka Day Performance

In my Year 3 I entered a competition for the first time. It was the Materials Lecture Competition. I participated in it out of curiosity and presented a topic related to spray-on solar cells which I had researched for my Generation, Transmission and Distribution of Electrical Power module. For this, I paid the price of late hours both at home and at the university and gruelling sessions with lecturers. In the course of this, I was forced to work efficiently in order to still meet all the demands of normal classes (lectures, lab sessions, assignment submissions, class tests and final exams). All of it paid off when in the end I won 2nd place in Malaysia. The Materials Lecture competition was a gateway to many other opportunities that came my way and the experience and knowledge I gained is invaluable.

A year down the line I selected a final year project that dealt with energy management and control system. The project required both engineering and programming skills and therefore required a lot of self-learning especially on the programming front. I found myself entering an event that allowed me to showcase my prototype. The ITEX event was very different from the Materials Lecture Competition in the sense that it was not only my presentation skills that were tested, but also my technical and creative capabilities. The sense of achievement where I was able to make theory meet practical so that what I imagined took on a tangible form, was more than unbelievable.

Joining this competition meant I was supposed to complete a 9-month project within 4 months. To keep this commitment and maintain academics as my number one priority, I ended up getting only a maximum of 3 hours of sleep every night. I knew that however thrilling winning competitions were, a degree would carry me further in my future and open more doors of opportunities for me.



Figure 2: 2nd Prize Materials Lecture Competition

After receiving a bronze medal in the ITEX competition I thought I had officially ended my challenge exploration. This was before a friend introduced me to the Maybank GO ahead Challenge. The challenge was not in my field of study (or so I thought), but in the interest of exploring all reaches of my capabilities I decided to enrol. Being an engineering student I was not acclimated to most of the terms used but it was an experience I was to forever remember. Drawing from my skills from the previous competitions and being able to think on the spot due to numerous class presentations, I was able to pass through the Campus level to Nationals Level and represent not only my country but also Malaysia in the Global Finals. At each stage I would ask myself what I was doing there, being amongst individuals of a business background though possessing only knowledge of engineering. In the end I gained my first trip to Indonesia and a job offer to work in one of the largest banks in Malaysia. The job offer came as a shock for two reasons; firstly, due to my nationality and secondly, my educational background.



Figure 3: Bronze Medal ITEX Competition

The impact of attending these competitions was immense on my experience. Still, it was my educational background that facilitated my success in them. I have always found much value inside the classroom as well outside it. Since I preferred getting knowledge first hand, my attendance never fell below 90%.

In the end my final words to anyone who is reading this and to my peers would be to not be afraid to apply themselves and seek new experiences outside your comfort zones because you never know what you are good at until you try everything. Who knows it might be you with the next fairy tale ending to your degree.

A Review of Energy Detection and Cyclostationary Sensing Techniques of Cognitive Radio Spectrum

Sami Helif, Raed Abdulla, Sathish Kumar

Abstract

Cognitive radio (CR) tends to be the key technology of future wireless networks as it provides the mechanism of enabling the spectrum sensing awareness. We have provided a study of some of the recent proposed enhancement of both energy detection and cyclostationary. Additionally, we have discussed the trade-off between design and performance efficiency of some of these enhanced sensing techniques.

Introduction

Spectrum underutilization acts as a tackle of the wireless technology advancement. It arises due to the wireless proliferation of wireless network technology and traffic volume versatile services. The rapid demand of higher data rate is the main reason that causes spectrum underutilization to come into existence during the last decade. Fig. 1 [1] shows the Spectrum utilization of band 0-6 GHz. According to FCC's reference, 15% to 85% represents the temporal and geographical variations range in utilizing licensed spectrum [2].

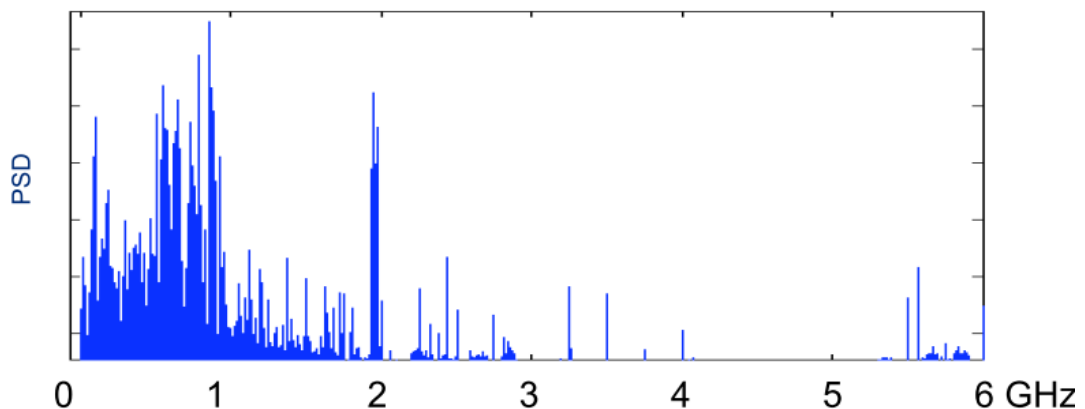

Freq (GHz)	0~1	1~2	2~3	3~4	4~5	5~6
Utilization(%)	54.4	35.1	7.6	0.25	0.128	4.6

Fig. 1. Spectrum utilization of band 0-6GHz [1].

Related Work

1. Cognitive Radio

CR is defined by Federal Communication Committee (FCC) as "A radio or a system that sense its operational electromagnetic environment and can dynamically and autonomously adjust its radio operating parameters to modify system operation, such as maximize throughput, mitigate interference, facilitate interoperability, and access secondary market" [5].

2. Spectrum Sensing

The process of detecting the presence or absence of primary user's signal in a certain band to determine the awareness of spectrum usage in the surrounding environment is known as spectrum sensing (SS). The necessity of obtaining a precise real-time decision to utilize a specific band without interfering PUs signal makes SS stage as the most critical factor to be determined in order to proceed further to next stages of cognitive duty cycle [6].

2.a. Energy Detection

Energy detect (ED) is also known as radiometry and it has been tagged as the most popular SS method due to its calculation simplicity and does not require any prior information of PU signal. It typically works with simplistic signal where the entire band to be sensed is either a noise or PU signal with noise as both signals have a constant power spectral density (PSD) [7], [8].

2.b. Cyclostationary Detection

The cyclic spectral analysis algorithms help to predict the correlation between the spectral components of signals. Determining the presence or absence of primary user is merely determining the presence or absence of the cyclostationary features in the observed stream of data that can be also modeled as a binary hypothesis testing. Prithiviraj and his research group proposed a detection method for sensing opportunistically the spectrum white spaces using the cyclostationary feature extraction technique [14]. The authors considered the method of cyclic spectrum estimation by implementing FFT Accumulation Method (FAM) method as illustrated in Fig. 2.

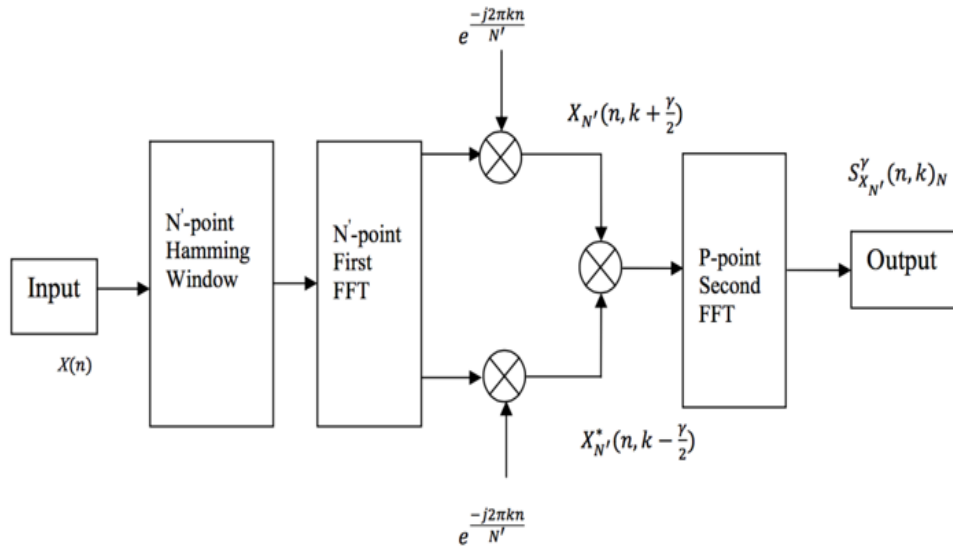

Fig. 3. Cyclostationary feature extraction technique using FAM

Conclusion

spectrum sensing has been a major point of research in the cognitive radio system. based on some recent researches, this paper has presented a review of two popular spectrum sensing techniques; energy detection and cyclostationary. moreover it discussed the trade-off that exists between design and performance efficiency of some of these enhanced sensing techniques.

References

- Arslan, Hüseyin, ed. Cognitive radio, software defined radio, and adaptive wireless systems. Vol. 10. Berlin: Springer, 2007.
- Q. Zhao and B. Sadler, "A survey of dynamic spectrum access," IEEE Signal Process. Mag., vol. 79, no. 3, pp. 79–89, May 2007.
- Mitola III, Joseph, and Gerald Q. Maguire Jr. "Cognitive radio: making software radios more personal." Personal Communications, IEEE 6.4 (1999): 13-18.



A.P.U.
ASIA PACIFIC UNIVERSITY
OF TECHNOLOGY & INNOVATION
SCHOOL OF ENGINEERING

SOE EVENTS

SoE Team Building



TEAM WORK IS THE ESSENCE TO QUALITY DELIVERY