



ENGINEERS INSIGHT

VOLUME 25
DEC 2020

Engineers Insight Editorial Board



Ts Harvin Kaur



Ts Dr Lau Chee Yong



Dr Shankar Duraikannan



Prof Ir Ts Dr Vinesh Thiruchelvam

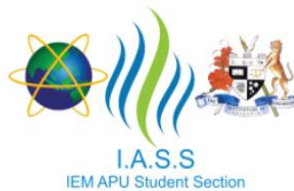

APU MALAYSIA
STUDENT CHAPTER



**Institution of
MECHANICAL
ENGINEERS**

Table of Content

No.	Item	Page Number
1	Article: Engineering Education in pre, during and post MCO by Ts. Dr. Lau Chee Yong	4 – 9
2	Article: 10 Years in Geology; Blessings and Struggles by Ailie Serasa	10 & 11
3	Article: Covid19-Time of Petroleum Industry and Future Forecast by Dr. Rahman Ashena	12
4	Article: Journey of a petroleum engineering student in APU by Syed Oubee	13 & 14
5	SoE Webinars	15 – 20
6	SPE Activities	21 – 33



“So, let’s think about this. Is COVID19 a good chance to speed up a new normal in engineering education?”

Ts Dr Lau Chee Yong, Senior Lecturer, SoE

Engineering Education in pre, during and post MCO

TS DR LAU CHEE YONG
DEC 2020

As we all know, the life before Movement Control Order (MCO) is the old normal that we have been living it on. We go to the classes; we do laboratory activities, and we take on exams. So, in this I would say we have already come out with a full and complete scheme of work in this education. And all this are being verified and endorsed by Engineering Accreditation Council (EAC). So basically, there are two main categories that is completing the scheme of work.

The first one is the assessment type. For your information, we have 2 different assessment strategy and now we are implementing them together. The first strategy is what we called formative assessment. Formative assessment is like the ongoing assessment that is being measure from time to time in a smaller portion. For example, it can be like a quiz which only weight 5% each, and you may have quizzes in every two weeks. In my university before when I was still a bachelor degree student, I experienced that we had a lot of quizzes almost in every week, and the grade is only counting the best 4 quizzes. The benefit of this kind of assessment is it helps students to identify their strengths and



weaknesses and the target area that needs extra attention. For example, maybe students are having problem to adapt into the assessment immediately, they might not do their best at their first attempt, and this scenario is very common, they might not know what the question is asking and how to answer to that. Therefore, more and more chances are given so they can adapt and perform better. This is simulating the machine learning where the error is being feedback and so the student can fix it in the next attempt.

The second type of assessment is what we call as summative assessment. This assessment is being taken at the end of the entire teaching and learning semester, and the students were always being tested with respective to certain benchmark or standard. In easier saying it is like final exam. Where you are not allowed to refer to anything and take on the assessment to test the knowledge that you know about the subject matter. Usually, this kind of assessment is being used to test the competencies of a skill. Meaning the skill should be embedded inside yourself, without taking any reference, and you are able to solve a problem based on that. This kind of assessment is already ongoing for a very long time and right now also being used in primary, secondary and tertiary education.

So, for now, the most common assessment type is the hybrid mode which involve both formative and summative assessment. Therefore, it is common to see a variety of assessment in a single module, for example consist of quiz, class test, laboratory report, assignment and at the end final exam. Moreover, with fine tune of the weightage of the assessment, we can harvest the maximum benefits from each type of the assessment.

So now let me explain the second category involved in formulating engineering education. The second category is what we called Problem Based Learning (PBL). As the name implies, problem-based learning is how we use a problem to provide the learning chances to students. For example, it can be a scenario given to student, like you have a sound clips which is very noisy, and students needs to find a solution to filter the noises. And the student need to demonstrate the fundamental engineering principle being conducted in formulating the methodology. Which means they cannot use any high-end audio software to filter the noise. Everything must be traceable.

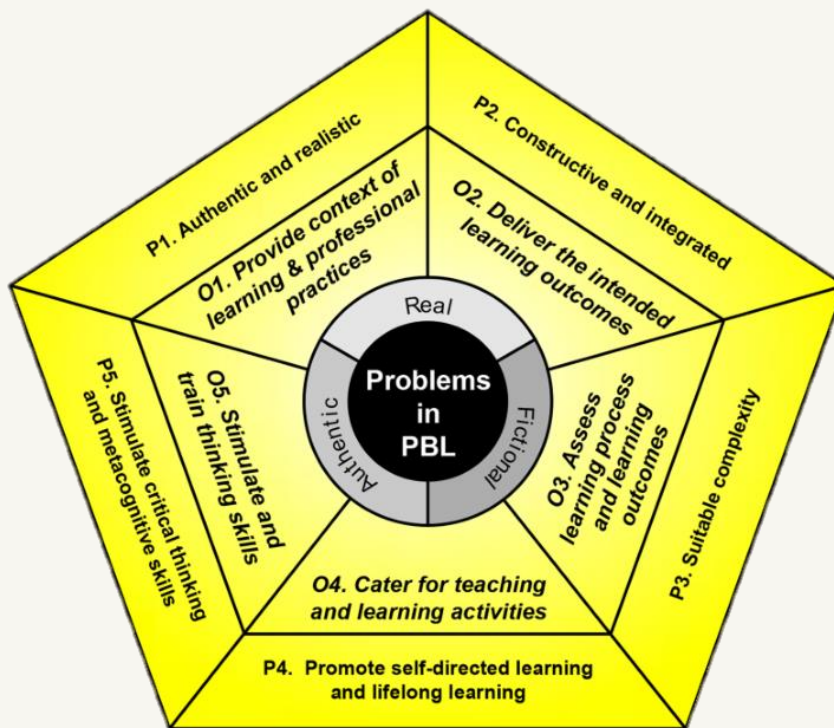

In PBL, usually there are three phases that every student must undergo. For the first phase, it is simple to meet the problem and identification of the root cause. For example, taking my own PBL which is about 10 years ago, I still remember that I was given a sound clips. If I'm not mistaken that time was about world cup time in Africa. My lecturer has given me a sound clip, which include the reporting of the newscaster, cheering from the crowd, and also the sound made by vuvuzela. Vuvuzela is a music instrument in Africa. So, the problem identification is you need to know what is a vuvuzela, what kind of sound it makes, and hence if you look deeper, u may analyze the spectrum in order to have a clear distinction between vuvuzela and the background noise.

The second phase is about synthesis of application. Once you have identified the target problem that you want to solve, then you must think of a solution to tackle it. I remember our group was using the fourier transform, in order to analyze the frequency element of different noises. And then we applied filter in order to isolate only the part that we want. Therefore, here, we have already adopted two different methods, which is fourier transform and filter, as in terms of high pass low pass filter. All these methodology was being taught in the class. And for the PBL, you were only being given with the problem, and the answer is always open ended. And this is actually the best phase which you can think out of a box. I remember when we were doing, we thought this is as easy as the methodology that we have already formulated. But when we applied these techniques, we found that the vuvuzela noises were still there. It somehow does not look exactly like what our lecturer has taught us. So therefore, what was on my mind was I used an audio software, called audacity to remove the vuvuzela noises. And that time the newscaster's voice was super clear. The outcome was good. Then I used the outcome to re-analyze and see the spectrum. We find that the spectrum doesn't really look like the one when we first applied the techniques. Therefore, we readjust the filter in order to obtain the similar spectrum like what we used audacity to do it. And at the end the effectiveness improved.

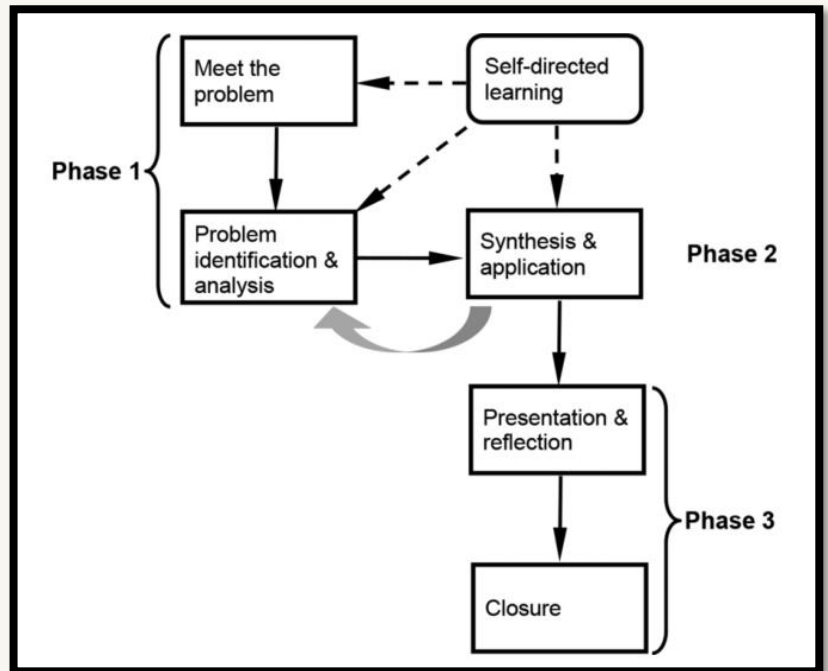

The phase 3 of PBL is the presentation and reflection. Once you have sorted out some methodology, you need to organize it and present them. You may have tested a lot of different strategy and some maybe useless. But the point taken might be worth a discussion. And from here, students can listen to the reflection given by the lecturer. It can be the order of methodology, any precaution to make, or how to measure the effectiveness. All these information are good conclusions to close a case. As the points taken might not only be useful in the problem.

Therefore, the essence here in PBL is the challenge in between. As you really doing it, you will discover more and more problem that you might not have imagined. The beauty of this process is, all the uncertainty is actually a very good teaching and learning lesson for students. As Engineering also implies troubleshooting. If there is a problem, we must be able to solve that using a standardize and organized method.

Is there any problem for the pre-MCO education as I mentioned just now? Generally speaking, from my experience, the main problem is from the student engagement. If the students are reluctant to be involved, it is hard to deliver the essence to them.



And as we all aware, our prime minister had announced the commencement of MCO, and it was started on 18th of March 2020. Some rules have been announced towards the university and it is greatly impacted us. All the lecturers must deliver their class online. I believe you all may have read the newspaper about the hardships of all teachers and lecturers have been experiencing. Maybe many there are some people thought teachers and lecturers are staying home doing nothing. But in fact, taking my own experience, we did more than before MCO. The main problem here is there is a sudden switch from traditional teaching to online teaching, we must quickly come out with a platform and the SOP in order to deliver the lecture. Also, the students are harder to manage because they are out of your visibility. Furthermore, the way of teaching must be redesigned because the usual way might not be easily transformed into online method. Also, the human-to-human engagement is becoming lesser. So, kudos to all the educator who put their effort in order to maintain the continuity of education.

For engineering education, my basis is still under the formative summative assessment, and problem-based learning. In this MCO period where all the classes are transformed to online class, there is not much effect on formative assessment. The consultation can be still given as usual. And the benefits of using the online platform is all your data could be retained and re-watched. You can record all the consultation moment with your students and that could be a reference from time to time. And during teaching and learning, the online whiteboard can save all the scribble that you have made, and student can then refer and re-watch all the information during their revision. After a complete process, all the recording can be further furnished and collected to become a complete course collection. This is a step to achieve e-Learning.

During this MCO and WFH period, we can't deny that we could save sometimes to avoid jam and travelling. The timing can be better adjusted and now students and lecturers are free from the location constraint. It is easier for students to reach out to lecturers.

There are some drawbacks that we can't deny from this online platform teaching and learning.

1. The first is the effect to the summative assessment. The main point of a summative assessment is to make sure the assessment environment is controlled. Like the students need to go to the exam hall. Need to remove hand phone and bring only pen and calculators. Only in this enclosed platform we can test the competencies of students. However, since everything has been moved online, we can't possibly keep an eye to every student while performing summative assessment. Exam paper are being distributed online, we can't avoid students copying from somewhere or discuss with friend. For the soft skill assessment involving presentation and demonstration, this is also being affected. When you are talking to them online, how can we ensure that they are not looking at another screen for the answers?
2. Secondly, students are restricted to access to laboratory. Throughout the entire engineering studies, it is crucial for students to have hands on experience. This include assessing to electrical machines, using PCB printer, 3D printer, sensors and actuator, specific software, CAD drawing, etching machine, and many more. All these hands-on experience is more effective compared to learning from slides.
3. Thirdly is about the team assignment. There are several assessments require them to perform in a team. There are a lot of soft skills are involved including project planning, identify strength and weakness, research the possibilities, teamwork etc. As MCO restricted our movement, students are not allowed to meet each other. Therefore, a lot of good chances have been wasted.

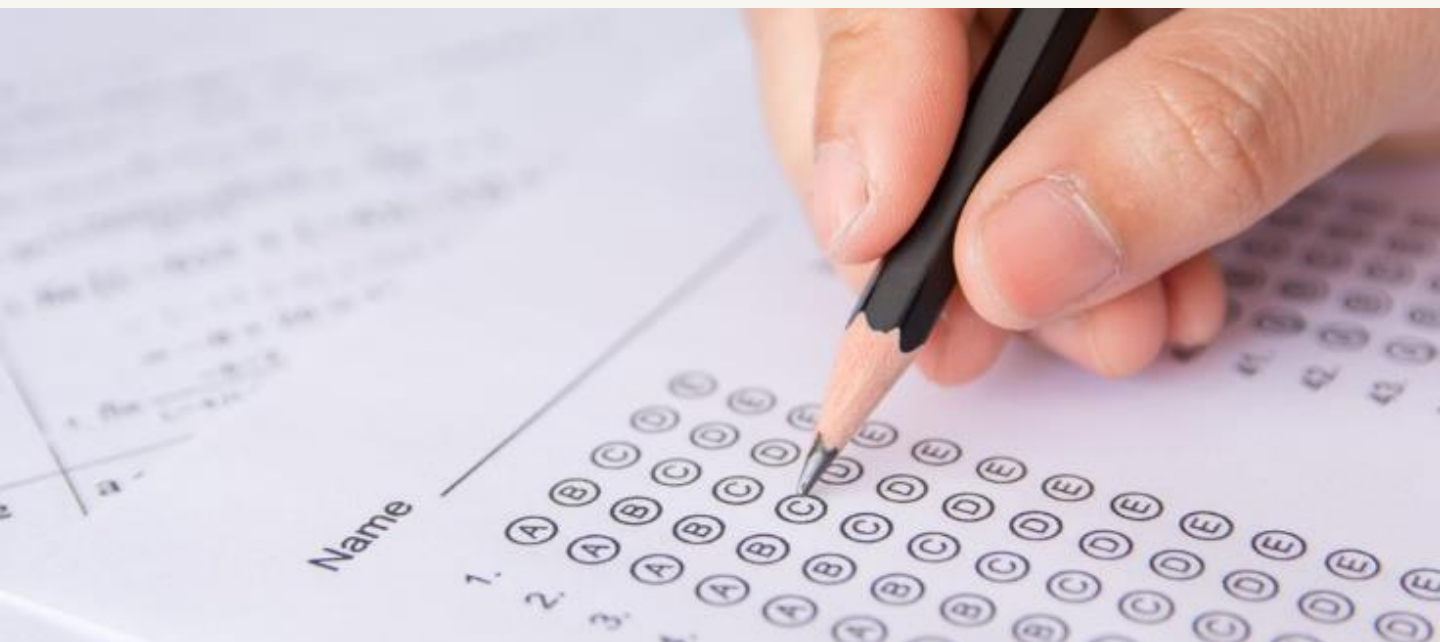

As now we are surviving from COVID19 and we can start to see the recovery, kudos to the front liners and the teams who fight rigorously for us. As we going back to our usual life, there are some points that I can suggest and propose

1. Summative assessment and PBL must go back to usual way. The reason is because the essence of the assessment type is being diluted by the online platform. In this online platform, we can't have a controlled and enclosed environment to proper test student's competencies. A lot of skills have to be tested on the spot in front of the assessor. If you say for example presentation, it is far different between a face-to-face demonstration and also a pre-recorded demonstration and being sent to lecturers. This summative assessment also is a way to train student to not overly rely on reference or assistance. The way we were doing this before MCO is already quite complete, and this is why I think it cannot be replaced in online platform.
2. However, formative assessment can be now simplified using online platform. One good thing about the online platform for example Microsoft teams and all that, all lectures and meetings can be recorded for future reference purposes. As formative assessment requires repetition for stronger memory, you can't possibly hire a lecturer to keep repeating the same thing all over and over

again. As the recording is always there, student can catch up the lesson by themselves. I personally experience that student consultation with lecturer for lesson is already reduced. And there are many things that we might not imagine about the benefits of incorporating technical software in our teaching is, we do not need to worry about collecting statistic. For example, you give a quiz online, it can be auto marked and generate the statistic of student answers. You will know which student perform better in which area. It provides a diagnostic to lecturers to have better control on the lesson and teaching speed. All these statistics were not being seen in normal usual teaching and learning method. So, the incorporation of these tools helps in formative assessment.

3. Thirdly is about achieving a totally independent e-learning. As we create the online classes during this period, we are actually creating content every day. Therefore, it is possible to create a space for student to complete a total independent learning. For example, a subject consist of 6 chapters maybe, maybe 1 of the chapter can be made totally independent learning by incorporating this e learning approach. Where the teaching videos are uploaded, the tracking can be done to see when the student has logged into it and study. And the formative assessment can be done via online quiz and so on. The result can be immediately tabulated to provide the learning effectiveness statistic. Therefore, depend on the nature of the subject, the entire workload of students can be now readjusted using this online platform as the independent e learning can be done at their own pace.

If you all still remember about 17 years ago, at that time we also having a similar pandemic situation. We were having SARS at that time. So actually there is one thing grew very fast after SARS. Do you know what was that? That is actually e-commerce. Before SARS we were so used to traditional way of transaction. We though online transaction was insecure, easily to be hacked and not safe. However, SARS actually speed up the process to adapt to e commerce. We never know nowadays we can be so used to have touch n go wallet, grab pay, boost etc. to be used in our daily lives, while 20 years ago we were still thinking it was insecure.

“So let's think about this. Is COVID19 a good chance to speed up a new normal in engineering education?”



"It was tiring and stressful but was it worth it? Definitely! "

Ailie Sofyaiana Serasa, Lecturer, SoE

10 Years in Geology; Blessings and Struggles

AILIE SOFYIANA SERASA
DEC 2020

It is a well-known saying within the Geology world that the best geologist is the one who has seen the most rocks! To be a geologist is to know how to "read" and "create the story" of Earth, using all the knowledge, observation and survey skills, as well as tools available. Geological fieldwork is a crucial part to understand rocks, geological structures, outcrop features and underground structures in their natural environment. Although majority of the work is done in the laboratory, going into the field to conduct surveys, to carry out mapping, and to collect samples are regarded as a necessity in Geology. There is no doubt that field is typically where geologists love to be. The passion for being in the field is usually what attracts aspiring geologists to the discipline. However, not many people like to work in dirty, inhospitable and remote environments. It requires geologist to become comfortable with working outdoors, and one can reasonably expect to be ready to work up to two (or more) weekend-long fieldwork trips.



I had the chance to be in the field for three grueling weeks, traveling for over 1,500 km for mapping and rock sampling. The experience was brutal, working every day from sunrise to sunset. I had my daily lunches of bread and water next to a busy North-South Expressway, at an abandoned quarry, inside a bat-infested limestone caves, at the Wang Kelian-Thailand border, at the Orang Asli settlement in Kelantan, and in the forest of Banjaran Titiwangsa and Mount Jerai. Dinner times were mostly spent on compiling daily fieldwork notes, finishing outcrop sketches and labeling samples. It was tiring and stressful but was it worth it? Definitely!

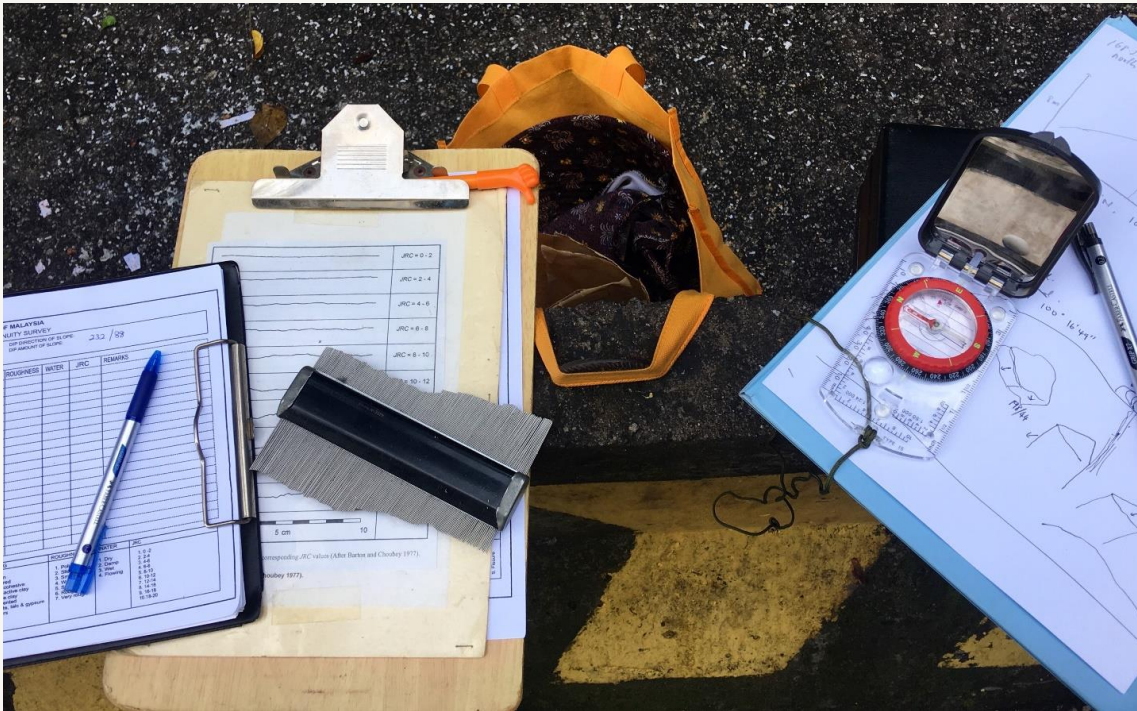

It requires hard labor and perseverance to work outdoor under hot sun and rain. Women are often associated with beauty, as fragile and delicate. These social prejudice results in men seeing it as difficulties for women to be allowed to work in the field. But this is not true. When outdoors, the Earth knows no difference between the X and Y chromosomes. Both men and women need to brave the unexpected bad weather, bad sunburn, wild monkeys and bugs, hammering and carrying rocks, hauling heavy gear and of course, using DIY camping toilets. Men should stop stereotyping women working outdoors, and women need to be tough, and comfortable working outdoors.

Field work experiences create opportunities that encourage critical thinking, teamwork, appreciation for nature, and increased scientific curiosity. Field studies require integration of cognitive, affective, and psycho-motor skills (Bloom et al., 1956; Bloom, 1965; Krathwohl et al., 1973; Simpson, 1972). It presents a holistic view of planet Earth and provides an unparalleled opportunity to study the real world. If you happen to know a geologist, join them for a short fieldwork!





“As Covid-19 may not be the last virus outbreak, preparation of the petroleum industry matters significantly to guarantee future industry resilience for future outbreaks.”

Dr Rahman Ashena, Senior Lecturer, SoE

Covid19-Time of Petroleum Industry and Future Forecast

DR RAHMAN ASHENA
DEC 2020

Since beginning of 2020, the outbreak of new Coronavirus (Covid-19) has caused a dramatic impact on people's lives and businesses/industries. Like most other industries, petroleum industry was adversely affected by the virus. As Covid-19 has made any environment unsafe where direct human-to-human contact is required, it has adversely affected the workplace of the petroleum and other related/dependent industries. The effects consist of employees' infections and their elimination or absence from the workplace, petroleum supply disruptions, less demand, low oil prices and bankruptcy of some petroleum companies.

To mitigate these issues, some ways were investigated by the industry to survive in the pandemic. These consisted of strict safe measures or protocols to protect the personnel, no or limited shift change of the personnel in the drilling and production sites, digital technologies, regulation of the market, etc. Expansion of digital technologies enabled distant personnel communications for maintaining the industry to continue running. Microchipping of people (like pets!) which were proposed by some

international companies as an excuse to overcome controlling such viruses, was gladly resisted by many nations and companies. In terms of business and overcoming excessively low oil prices, contribution of international organizations such as OPEC and merging with Non-OPEC ones (especially Russia) helped petroleum producers and consumers reach consensus, which mattered for regulation of the market and survival of the industry/business, particularly for producers.

Though this malicious virus still takes many fatalities everyday globally, it will inevitably go away one day (naturally or with human interference/vaccine). Let's imagine that happens the first half of 2021. Following the virus, with removal of face coverings and people going driving, travelling, shopping, etc., the global economy would start to rise up again, despite negative forces against the petroleum industry. This rise is identical to greater demand for oil and gas. With possible US presidency of Joe Biden and his so-called clean energy strategies and anti hydro-fracking and arctic activities and strictness to give out oil and gas leases, it is expected 2-3 million barrels of oil be removed from US domestic production especially from oil shales (supply reduction). However, US may allow Venezuela and Iran to start exporting again (increase in supply). As a result, it is not clear how the net supply would finally stay. Therefore, comparing supply and demand and other effects (political, etc.), the market would balance. Anyway, it seems a boom in and gas activities would appear soon in 2021. As an example, for post-Covid19 time, UAE is planning and getting reading to drill around 100 wells each, the same is almost for Saudi Arabia.

As Covid-19 may not be the last virus outbreak, preparation of the petroleum industry matters significantly to guarantee future industry resilience for future outbreaks.

“The reason why Oil & Gas Industry is special to me is because there is no definite answer in any book.”

Syed Oubee, Petroleum Engineering Graduate from APU, Class of 2020

Journey of a petroleum engineering student in APU

SYED OURBEE KHADRI GRADUATE PETROLEUM ENGINEER FROM APU CLASS OF 2020

Hi!, my name is Syed Oubee Khadri just finishing my degree in Petroleum Engineering. This feeling on graduating during Covid-19 times is not for the quality of what I studied or what difficulties I and my friends went through but the end of a journey without finishing at the highest note. A typical student is motivated, but also procrastination, same as me. I started my degree in November 2016 at the old campus. I had no specific idea how petroleum engineering was taught in universities. Furthermore, I wanted to study chemical engineering instead but never got the chance for my lower high school marks in contrast. The aspect that piqued my interest in my first year of the degree was the module fundamentals of petroleum engineering. It energized my interest with what is an engineer's work in oil and gas industry. I looked upto certain seniors of mine during my first semester. During the first orientation, it showed how students had their own potential to be met in APU. Seeing Zaki Shamsuddin Mukadam, Chama Serenje and Dineshaa Gungasagaran who was actually hosting the orientation I had an idea how my remaining time in university must go like. This also made me look upto them.

I started my degree with normal motivation and interest in co-curricular activities. I understood why students were also focusing on such activities when I saw my seniors developing their skills and connections at a very higher rate than other students. So, I started shadowing them under IEM APU Student Section. I organized three workshops on my own which got me a recommendation from them for the next committee. This developed my communications skills from none to some. There is one thing that my high school and secondary school messed up or didn't help me, which was in communication skills. I understood that this was an imperative aspect for every professional in the oil and gas industry. APU developed my presentation and professionalism from the moment I entered the campus.

Coming to my second year, I started engrossing myself more in such activities as my interest was lowered in common modules. I joined Library as an assistant which developed my time management skills and to work under pressure and got selected as Vice Chairman of IEM APU Student Section. During this year, I focused on such activities more than my studies, which was in fact a bad decision. But the complete development and exposure from IASS and being a librarian, I had during this year would trump my results in academics. This gave me experience in how to deal with extra pressure from each side while also being calm.

Until the first semester of my third year I handled a certain number of events and activities under IASS including OG1.0, which was my favorite as I had done it for my department. I requested help from all the present lecturers in Petroleum engineering department namely Ms. Ailie Sofyaiana Serasa, Ts. Harvin Kaur and Dr. Mahmood. This was a one-day event with three workshops and one competition during a weekend. Upto 50% of petroleum engineering students at that time attended the event which made it a great success and got the attention of my lecturers for SPE establishment in APU.

SPE or Society of Petroleum Engineers is a nonprofit organization that provides a common ground for student and professionals alike. Being a member of such an organization is a huge boost to anyone aiming to join Oil & Gas Industry or who is already present in it. Similar organizations are present for other majors, but the uniqueness in SPE were both for Students and Professionals. Each had an equal voice and contribution towards the improvement and innovation of the industry. Students such as myself, who haven't achieved any thing yet or did not have any professional experience can communicate with high-ranking professionals from companies like Petronas, Shell, Schlumberger etc. The plan was made to establish the student chapter just before my internship. I had to decide whether to pursue it while completing my final year or just focus on the academics. I chose the former as I would come to a point where I can prove that I can work under pressure and I can work in the industry. Oil & Gas industry is filled of individuals that work for months without having to go home but love every second of it. This decision was one of my best decisions as while I was having my industry training, I met many industry professionals who helped me to establish the student chapter. In all honesty it took me upto three tries to establish the student chapter as each time I missed out a detail or a requirement. Third time was the charm in establishing the student chapter on February 2020 with Ts. Harvin Kaur being our Faculty Advisor and Malek Marwan being the Vice President.

The complete journey of my degree was something out of ordinary because of all the things I have learnt throughout it. I tried to fill the voids in my skillset and knowledge, developed additional skills, started networking with people and understood the passion behind anything. As I am finishing my studies I hope, and I will try to put all what I have learnt in my occupation. The reason why Oil & Gas Industry is special to me is because there is no definite answer in any book. There is always a perspective on how anything that can be solved unlike other engineering majors where an answer is repeated until it decays, or until an innovation is done. Trying to understand the big picture and finding new people who mentored me until today and I hope in the future as well, will always make me stick to the industry.

Thank you, APU!

WORKSHOP ON SOLIDWORKS SOFTWARE

Organized by **APU IMechE student chapter and IMechE Malaysian Branch**

On 19th September 2020 from 10am to 12noon

**DR. ARUN SEERALAN
SEPTEMBER 2020**

The workshop hosted jointly by APU IMechE student chapter and IMechE Malaysian Branch and the trainer for the this event Dr. Arun Seeralan Balakrishnan. So students from different universities of Malaysia joint the workshop and learnt about the basic tools and technics available in Solidworks software. The hands on workshop was conducted online through MS.Teams. there were nearly 16 students benefited from this event. Few students from APU also took part and learnt about to produce the 3D components with their respective Engineering drawing according to Industrial standards. The hands-on workshop event was conducted for the time period of 2hrs from 10am to 12 noon on 19th September 2020. This hands-on workshop helped to students in order to enhance their knowledge to produce engineering drawing for 3D objects and how to interpret with the given Engineering drawing. At the end students were able to enhance their knowledge how to use the Solidworks software in more efficient way according to the Industrial standards.



Webinar session

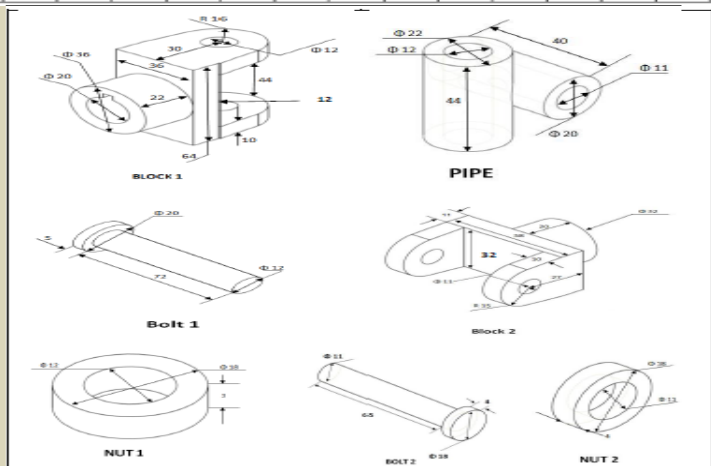
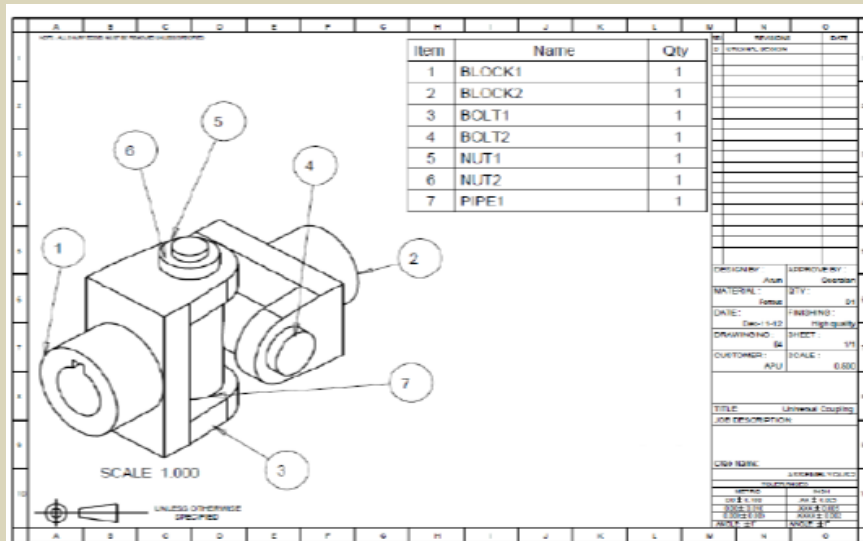

3D component drawing during workshop

WORKSHOP ON ANALOGUE ELECTRONICS

On 9TH October 2020 from 10am to 12noon



ASSOC. PROF. DR. LAI NAI SHYAN
OCTOBER 2020

There was a workshop on Analogue Electronics held on the 9th October 2020. The purpose of this workshop is for students to experience how to build analogue circuits (prototype) which they missed during the MCO.



Webinar session



Webinar poster

ENGINEERING ETHICS: INTO THE FUTURE

**ASSOC. PROF. DR.
SATHISH KUMAR
SELVAPERUMAL
NOVEMBER 2020**

Final Year Students of Project Phase 2 of APU4F2006 EEE-PE-ME-TE and Project Phase 1 of APU4F2010 EEE-PE-ME-TE attended a Webinar on 4th Nov 2020 on “Engineering Ethics: into the Future” by a panel of 3 members namely, Panel 1: Ir. Professor Dr. Rajkumar Durairaj Dean (Academic Quality Assurance), Division of Quality Assurance, he is the Associate Director (Materials and Manufacturing) with the Engineering Accreditation Department, Board of Engineers Malaysia (BEM). Panel 2: Ir. Francis Ngiam A licensed civil engineer in Arkansas, California & Malaysia, he started practicing engineering in 1997. He is involved in Green Infrastructure & Green Building Design & Construction, and is the co-founder of GPROTD Resources, a training and consulting company. Panel 3: Amru Daud Involved in the SHE Managerial role in CCM Chemicals, Amru started his career in 2000 as a process engineer. He was appointed as Factory Manager in 2002 for Gold Coin Specialties S/B at the age of 26, marking his management career. His expertise is in process engineering, Process & Occupational Safety.

Engineering ethics is crucial for engineers because it sets the standards for professional practice. It is an essential part of professional education to help future engineers deal with issues they will face in professional practice. This special forum will discuss important perspectives such as: What is engineering ethics? Why should it be emphasized? Real examples we never imagine? Will engineering ethics still be important in the future and how to deal with it?

Those students who attended and registered were given E-certs.

UTM CEE WEBINAR SERIES **INDUSTRIAL SEMINAR & PROFESSION**

ENGINEERING ETHICS: INTO THE FUTURE

4 Nov 2020
2.00 p.m (MYT)

LIVE YouTube
<https://bit.ly/cee-utm>
Centre for Engineering Education
Universiti Teknologi Malaysia

Ir. Prof. Dr. Rajkumar Durairaj
Dean (Academic Quality Assurance)
Universiti Tunku Abdul Rahman (UTAR)

Ir. Francis Ngiam Kee Hwee
Trainer/Consultant
GPROTD RESOURCES

Ir. Dr. Zaki Yamani Zakaria
Senior Lecturer/ Fellow
Centre for Engineering Education, UTM

Mr. Amru Daud
Asst. Manager SHE
CCM Chemicals Sdn Bhd

For more information Visit us at <http://tree.utm.my/blog/webinar/>

UNCONVENTIONAL HYDROCARBONS AND ITS POTENTIAL

On 19TH NOVEMBER 2020 from 2pm to 4pm

TS. HARVIN KAUR
NOVEMBER 2020



A.P.U.
ASIA PACIFIC UNIVERSITY
OF TECHNOLOGY & INNOVATION

School of Engineering

Unconventional Hydrocarbons and Its Potential

In the continuing drive to meet the world's future energy needs, few can have missed the increased recent prominence of unconventional hydrocarbons. The extraction of resources such as shale gas, using techniques like hydraulic fracturing (or fracking) has gained attention from around the world, both for its potential to fulfil our energy requirements, as well as due to concerns around possible environmental impacts.



Asia Pacific University of Technology and Innovation
19th November 2020 (Thursday) 2pm to 4pm

Speaker:



Pn Mazlin bt Idress
Lecturer
Universiti Teknologi
PETRONAS

- Unconventional hydrocarbons are sources of oil and gas which require methods for extraction which are not normally necessary in the conventional extraction of hydrocarbons.
- Sources of unconventional oil and gas include: Shale gas, shale oil, tight sands, clathrates (gas hydrates), coal bed methane (CBM).
- Extraction methods include "unconventional" techniques. In shale gas these techniques are a combination of commonly used conventional methods: Horizontal drilling and hydraulic fracturing (or fracing / fracking).

The webinar was held on 19th November and it had attracted more than 20 viewers online on Youtube and Facebook.

OIL AND GAS PROCESS ENGINEERING

On 21ST NOVEMBER 2020 from 10am to 11.30am

TS. HARVIN KAUR
NOVEMBER 2020



School of Engineering

Oil and Gas Process Engineering

Process Engineering is at work during all stages of a continuous manufacturing process. These engineers can be designing innovative processes and equipment for a new facility or they can be involved in the modification and optimization of equipment and processes that are already in place.



Asia Pacific University of Technology and Innovation
21st November 2020 (Saturday) 10:00am to 11:30am

Speaker:



**Ts. Dhanaraj
Turunawarasu**
Senior Flow Assurance
Consultant
Intecsea (Advisian)

Process Engineering is vital to offshore activities across the business and helps with the development and production of raw hydrocarbons and the subsequent processing into commercial products. With a curious mind you could be part of designing and optimizing chemical processes, and the operation of equipment and facilities; or analyzing and interpreting laboratory and plant data. Our process engineers also provide technical support to oil and gas production facilities, refineries and chemical plants (both onshore and offshore); ensure the technical integrity of plants and new projects; advise on process safety issues, and commission new installations.

The webinar was held on 21st November and it had attracted more than 30 viewers online on Youtube and Facebook.

FLOW ASSURANCE (WAX)

On 22ND NOVEMBER 2020 from 10am to 11.30am



School of Engineering

Flow Assurance (Wax)

Flow assurance involves ensuring fluid flow in well and pipelines. In a deep cold environment wax deposition can form and easily reduce the flow. When the temperature drops below wax appearance temperature, wax particles precipitate out of solution, crystallize and form a gel. Deposition of these gels makes flow through pipelines difficult and challenging which leads to increases in operational and remedial costs. Pipeline failures in this condition is a potential threat in some cases such as restart of the production. Reliable experimental approaches mimicking pipeline conditions for wax studies are critical to reduce the cost of production and transportation of crude oil.



Asia Pacific University of Technology and Innovation
22nd November 2020 (Sunday) 10:00am to 11:30am

Speaker:



**Ts. Dhanaraj
Turunawarasu**
Senior Flow Assurance
Consultant
Intecsea (Advisian)

TS. HARVIN KAUR
NOVEMBER 2020

As offshore activities continue to progress into deepwater, ensuring the well stream flow from downhole to process facilities is becoming a critical issue for development of the reservoirs. Flow assurance is the technology and ability to transport hydrocarbon fluids from reservoir to export point, economically, over the life of a field, and in all kinds of environment. Flow assurance addresses broad aspects of the problems and solutions of flow distortion, including solid depositions of waxes, hydrates, paraffins, asphaltenes, and scales from reservoir to topsides. When physical conditions are "wrong," hydrates form, or waxes and asphaltenes come out of the well stream fluids, plugging up flowlines and processing equipment. Cleaning of a plugged flowline/pipeline is often very costly, time consuming, and technically challenging. Production must be interrupted and may sometimes require a complete shutdown. Maintenance and repair methods get more complicated and expensive as the water depth increases. Procedures for intervention also need to be pre-considered because these procedures may influence the overall system design including Christmas trees and flowlines.

As a solid organic phase, mainly long-chain n-alkanes (C16-C80+), wax comprises a mixture of components. In oils, wax crystallizes within the fluid as the fluid temperature drops to below the cloud point. However, it only deposits on the pipe wall when the wall temperature is below the cloud point and colder than the bulk fluid. The wax crystallization process develops in three stages.

The webinar was held on 22ND November and it had attracted more than 30 viewers online on Youtube and Facebook.

Basketball Science & Master Mind

Asia Pacific University of Technology and Innovation
23rd September 2020, 11am to 12 noon



**TS. ALEXANDER CHEE HON
CHEONG
SEPTEMBER 2020**

Organizer:

1. Jordan Leonard Yeo (TP058446)
2. Antonnio Lim Jigong (TP060348)

Title of the webinar:

Basketball and Technology

Attendees: 25 students

Outline:

- History
- Basketball technology objectives
- Tools Breakdown:
 1. Personal tools
 2. Team tools
 3. Game tools
- Conclusion
- Q&A

APU MALAYSIA
STUDENT CHAPTER

Institution of
**MECHANICAL
ENGINEERS**

Institution of Mechanical Engineers (IMechE)

SPEAK OUT COMPETITION FOR ENGINEERS

DR. ARUN SEERALAN
SEPTEMBER 2020

Organized by IMechE Malaysian Branch

The speak out for engineers were hosted every year by IMechE Malaysian branch and this competition cultivates the talent in young engineers to communicate in more appropriate way. The judging of this competition was considered about various skills like technical knowledge, language usage and responds to the questions raised in the Q&A session. So, from SOE Ms. Tanuja Kaur a student of Engineering has participated and reached until to the final. Ms. Tanuja Kaur is also an active member of APU IMechE student chapter and that paved a way for her to join the competition. She did choose a topic related to 3D printing technology as an emerging Technology and continuous research has been going on. The way in which she presented and answered the questions helped her to clear all preliminary rounds with other competitors and reached the finals.



APU Representation for the competition

APU MALAYSIA
STUDENT CHAPTER

**Institution of
MECHANICAL
ENGINEERS**

Institution of Mechanical Engineers (IMechE)

DESIGN COMPETITION – 2020

Organized by IMechE Malaysian Branch

DR. ARUN SEERALAN
SEPTEMBER 2020

Design skill competition was hosted by IMechE Malaysian branch for young engineers to propose a system that can operate the Airconditioning system using the renewable energy that is vastly available in surrounding. This helps the multi-disciplinary engineering students to join and propose a system with different technical knowledge as background. So, a team of 3 students joined and proposed a system that can operated with the existing renewable resources and helps to keep the environment clean and healthy. The final proposed concept was submitted to YMS of IMechE and hoping to be selected for the next round. This competition helps students to work in a group and share their knowledge according to the limitations provided. The above design is the proposed method by students of Engineering and waiting for the results to be announced.

Team members for this project are:

- 1) Rabah Anakkachery
- 2) Zifaan Abdulla
- 3) Mohamed Mafaz Mohamed Ahsan

Institution of MECHANICAL ENGINEERS **YMS Malaysia**

Design Competition

Challenge: To develop a small-scale interior air cooling device which uses energy generated from renewable energy sources.

Stage 1 14 August till 16 October 2020
Registration & Proposal Submission

Stage 1 18 October till 8 November 2020
Proposal Evaluation

Top 5 Finalists 9 November till 13 November 2020
Announcement of Finalist and Prototype Funding

Stage 2 16 January 2021
Final Evaluation

Stage 2 9 November till 15 January 2021
Industrial Mentorship & Prototyping

T&C

- 2 - 4 participants per team, with at least one of the team members is a registered IMechE Young Member (Affiliate/Associate*/MEMechE*).
- *Must be registered with IMechE for more than 12 years.
- Each team is required to submit one (1) proposal discussing and detailing their ideas and design.
- The proposal shall be submitted to YMS Malaysia by 16th October 2020.
- Prototype grant for top 5 finalist to transform their design into reality and stand a chance to win at the final evaluation!

For more information, please email us at: imecheydesigncompetition@gmail.com

Improving the world through engineering

Prize money up for grabs!

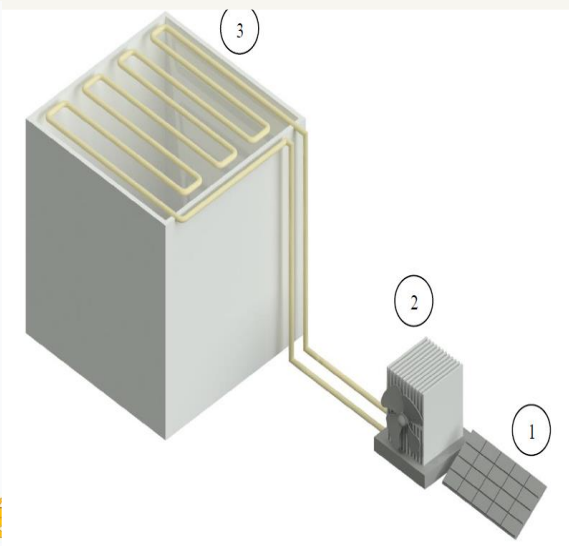

APU Representation for the competition

APU MALAYSIA
STUDENT CHAPTER

Institution of
**MECHANICAL
ENGINEERS**

Institution of Mechanical Engineers (IMechE)

**DESIGN SKILL COMPETITION 26th
September 2020**

DR. ARUN SEERALAN
SEPTEMBER 2020

**Organized by APU IMechE student chapter & IMechE
Malaysian Branch**

Design skill competition aims to cultivate teamwork, use their imagination and analytical skills to invent, design and turn ideas into products among young Engineers. The design concept has been provided to all teams on the spot, explanation and time for login into the system will be provided of 30mins, the competition time slot has been allocated uniformly to all teams for 3hrs from time of start. Today, virtually every aspect of our daily lives is enabled in some way by Engineers. There were 13 teams participated through MS-Teams and using solid works software. The event was organized by the student members from APU – IMechE student chapters. So, students learnt how to organize an event online and how to resolve the technical issues faced during the event. The first two place were bagged by APU teams and third place was held by Nottingham university. All participants were provided with the certification of appreciation for joining the event.

Results:

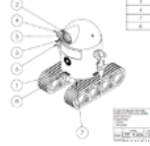
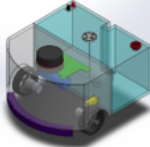
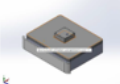
No:	Awards	Assembly view
1)	First place – GAMMA - APU	
2)	Second place – LT works – APU	
3)	Third place – Nottingham university	

APU Representation for the competition

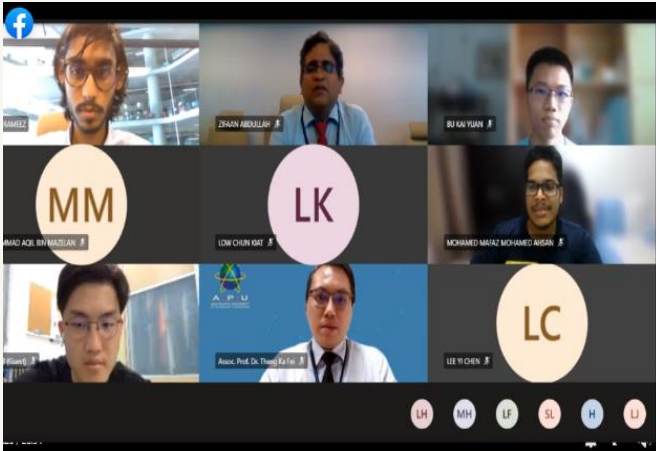

Picture gallery of Design Skill Competition 2020

INOTECH 2020

**LIM MING MING
TS DR. YVETTE SHAAN-
LI SUSIAPAN
OCTOBER 2020**

We are surrounded by revolutionary innovations every day. Some are inspirational, reminding us to strive for the impossible; Some emphasis done on sustainable design, reminding us that we human only have one home - Earth. Future engineers have obligations that are centered around solving modern days' issues and improve the quality of many lives. Innovation requires leap of faith and the desire to try new approaches; in conjunction with this, InoTech 2020 was held and organized in APU for innovative young engineering and computing students to exhibit their talents on recent technologies in their relevant field of engineering in the Invention & Innovation Exhibition.

This year's InoTech 2020, held on 16th of October 2020 was jointly organized with the Institute of Engineers, Malaysia (IEM), supported by the Institution of Mechanical Engineers, Malaysia (IMechE).

This year, the event judging was conducted fully online and the results were announced through live streaming. Two James Dyson Foundation engineers were among the panel of judges which rewarded students with a bursary of RM500 each to the top 5 contestants in the Special James Dyson category. The contest had over 70 project participations.

It was our great honor to have Mr. Affendi Zamzam—Engineering Manager, Global Engineering, and Operations of Dyson to inspire and motivate our young and enthusiastic engineering students to strive for a better future with sustainability in mind. It was not an easy journey for Dyson as Mr. Affendi shared with us that even an organization as significant as Dyson today, was once underestimated by investors and stakeholders. It is the spirit of the Founder, James Dyson who believed in the idea of making thought into reality; even though it appeared impossible. After numerous trials and error, Dyson technology has become well-known for its sustainable engineering design process.

Mr. Affendi was impressed by the projects done by our passionate group of talents and praised them for creating constructive ideas with sustainability in mind. He also gave an honorable mention to our APU national winners who designed 'KUNO', a Zero-Energy Cooler Fridge which won the James Dyson Award 2020 for sustainable design.

The event was followed by the award-giving ceremony to the winners. Mr. Affendi encouraged the top 5 winners to participate in the upcoming James Dyson Award for a more exciting journey to challenge themselves and generate media exposure to kick-start their careers. The application will be open every year from March to July for future engineering students to join. He also comforted those who did not perform well by giving them advice to never give up and learn from your failure; just like James Dyson who created more than 5,000 prototypes before becoming successful. The main takeaway point from his inspiring speech was - sustainable design is the future, because if we don't take care of our home, who will?

Congratulations to this year's winners!

Project Title	Team Members
IoT Based Smart Road Transport Monitoring System for Food Industry (Champion)	TAI JIA XUN ABDULHAFIZ MOHAMEDARIF DAWOOD YUMU NOMA SELVENDRAN A/L G. PANIR SELVAM AKSHEY KUMAR A/L MAGENTHIRAN
A Low Cost Stabilizing Spoon for People with Parkinson's Disease (2 nd place)	AMMAR NAZRIN BIN HAJI RAMLI
Control and Monitoring System of Mechanised Musical Instruments (3 rd place)	CHAN HONG YI
Reduce Carbon Footprint in Meat Processing Industry with IoT Application (4 th place)	MUHAMMAD AFIQ HANIF BIN MOHD ZAIDI MUHAMMAD IRSYAD HAZIQ BIN MD AZHAR ZAFIRAH IZNI BINTI ZAINUDIN HARVEET SINGH SANDHU A/L RANDHIR SINGH MUHAMMAD ZULKHAIRI BIN CHE MI
Human Posture Recognition During Weightlifting/Exercising using CNN (5 th place)	ABDUL WADOOD
Condition Monitoring of Frozen Storage for Energy Optimization (6 th place)	KUAN HUI WING
Development of Indoor Fogponics Vertical Farm with IoT (Consolation)	LIM WEI LUN TANG SHAU HAN CHANG TECK SEONG DESMOND LOH HOU YIN MIKKI LOO HOW WEN
Autonomous Drone for Power Line Inspection with IoT Monitoring (Consolation)	MUZAMIL ADEEB MOHAMED MAFAZ MOHAMED AHSAN PONG WEI XIANG CHAN HONG YI NEW WEH XIANG
Hand Gesture Translator for Hearing and Speech Impaired People (Consolation)	CHARLES ROHAN LEE
Acoustic Energy Harvesting (Consolation)	LEANDRE MARIE MUHIRWA

Society of Petroleum Engineers (SPE 2020)



SPECTAXU 2020

**MAJDULINE JUBARAH
BASEL GAD
TS. HARVIN KAUR
NOVEMBER 2020**

SPECTAXU 2020 or SPE Collaboration of Petroleum & Energy Competitions from APU & UIR 2020 was a collaboration between our partner university – Universiti Islam Riau held during the months of November and December 2020. The event was born of the idea that both universities were partners and as well as their travel to APU which also included Student chapters having a get together. There was this idea of collaborating for a major event that would include competition and new model of events. Due to the pandemic, it was downtrodden to virtual sessions. Both universities brought together certain competitions and other technical events. The main them was the Revolution in Oil & Gas Industry which was observed throughout this year during the downturn and recovery.

SPECTAXU 2020 included 2 competitions, a grand seminar and a technical workshop. SPE APU SC developed a competition known as Presentation Now, which majorly challenged the student's communication skills. The student could bring their creativity in order to convey a message or a simple solution.

Four teams for the competition were from both Malaysia & Indonesia. The champion was decided to be Islamic University of Indonesia. Three lecturers from APU were asked to be the judges for this competition – Ms. Ailie Sofyaiana Serasa, Dr. Morakinyo Dada & Dr Amin Shahbazi. The event was distributed into two segments being a video submission and a live Q&A. The video submissions made by the teams were of 20 minutes with a topic that would relate to Petroleum Engineering. As the marking scheme was distributed 60% being communication skills and 40% being Technical Knowledge. The second segment included a live Q&A between the judges and the participants. This was posted live on SPE APU SC social media.

The grand Seminar was collectively organized by both Student chapters, in which each student chapter had to provide one speaker for it. The topic was based upon the theme of the complete event being “improving knowledge to face the Revolution in Oil & Gas Industry”. The speaker from SPE APU SC's side was Mr. Mohd Zaim Awang Pon. He is a well-known reservoir engineer in industry, currently a consultant from AiSera. Well-rounded experienced Reservoir Engineer with 22 years solid technical experience delivering results in integrated teams of exploration, production, studies and new venture and now Artificial Intelligence. He is the content creator of the course Reservoir Physics and Practical Reservoir Simulation. He is also passionate about technical problem solving and algorithms and have formulated the next generation Artificial Intelligence technology (patent pending). Solid theoretical grounding with a BSc in Petroleum Engineering from the University of Texas at Austin. Just after 5 years joining Shell, he was selected to be in the Top 100 Shell Malaysia employees to receive international exposure in the "Olympic 100" programme. He has acquired hands-on experience with oil and gas, clastic and carbonate, green and brown, marginal and giant fields, offshore and onshore production and field development planning around the world. The speaker from SPE UIR's side was Ismail Ibnu Haris Al Haj who is a petroleum engineer currently working at Chevron.

He is a well-known reservoir engineer as well in his own regards by developing secondary recovery for Chevron's fields. With 10 years of experience and being known as a senior executive of Chevron, he provided a technical aspect to the complete seminar. Both speakers collectively and with a partnered speech provided both technical and psychological was to deal and to develop as a student for the upcoming era in the oil and gas industry. The need for data-oriented actions and operations and the initial requisites for such analysis are part of the criteria which are not typically covered in Universities. A grand total of 90 Students attended collectively from Indonesia & Malaysia which was the highest seconding to SPE Joint Webinars done during the same time.

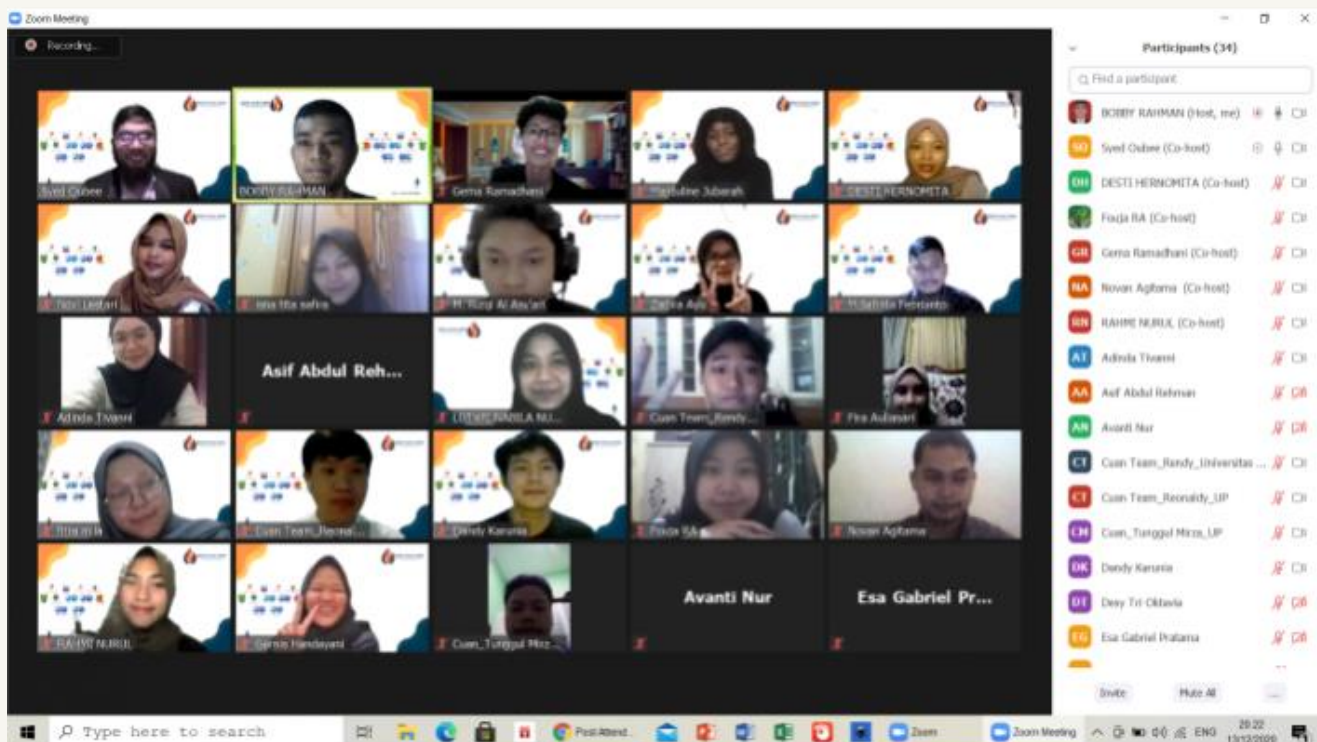

Grand Seminar of SPECTAXU 2020

Society of Petroleum Engineers (SPE 2020)



SPE JOINT WEBINARS

**ABDALLAH EL
BADAoui
AILIE SOFYAIANA
NOVEMBER 2020**

SPE Joint Webinars was a series of technical and career development talks that were organized by SPE APU SC and SPE Northern Emirates. This event marked the first collaboration between SPE APU SC and a well known SPE Regional Section. It also marked the first time a SPE Distinguished Lecturer joined as a speaker for the event. A total of seven speakers who are distinguished professionals in their own regards came together for such a harmonious event. This was designed to capture the attention of students by both technical knowledge delivery as well as career development insights that can be followed. The event was done throughout the last two weeks of November, with each two-day gap between sessions. It was sponsored by Hunting Oil.

Under the guidance of Ms. Ailie Sofyaiana Serasa (Program Leader of Petroleum Engineering, APU) and Mr. Izwan Adnan (Sr. Reservoir Engineer, Dragon Oil) with the leadership of Abdallah El Badaoui this event was brought into fruition. Speakers that were invited for this event are as follows:

James Barry (Novel Techniques for Curing Lost Circulation and Achieving Zonal Isolation in the Middle East)

Diverse background results-driven manager with a comprehensive experience in team building, mentoring coaching and business development expertise in the public and private sectors. Internationally experienced, comfortable with extensive travel. Effective communicator regardless of culture or language. Recognized as an expert in down hole technical and program development, business plan execution, logistics, safety and quality. A Multi-discipline manager with over 25 years of experience, 15 in the Oil and Gas business.

Yohanes Nuwara (Python Awareness for Exploration and Production: Students and Professionals)

An experienced Geophysicist and a programmer with comprehensive knowledge and a great portfolio including different project spanning from reservoir simulation in python to well testing analysis. Complete degree in Geophysical Engineering while receiving the award for outstanding achievement. Presently working as a trainer with Piopetro and a CO2 sequestration Engineer with RITE & OYO Corporation.

Karen Ochie (Internships: Your First Head Start or Not)

An experienced petroleum engineer currently working at shell as a Volumes Analyst & Planning Engineer.

Raffik Lazar (geologist 4.0: being a reservoir geologist in this era of change)

He is a carbonate geologist and geomodeller by background, with 15 years in the industry, mostly with Shell International and currently with GeomodL International. 4 years ago, He decided to take matters in his own hands by creating GeomodL International. Aside of his technical duties, He is learning on the job how to run a company on a day-to-day basis, elaborate and translate into reality a growth strategy, link and connect with likeminded people and key decision makers.

Roger Findlay (Optimizing Reservoir Performance and Recovery Rates)

With 18 years of experience, He is the present general manager of Organic Oil Recovery which is a subsidiary of Hunting Oil. Experienced and well versed in project management, he has worked in GE oil & gas, Bp and Hunting oil as a project manager.

Dr. Rahman Ashena (Optimization of Drilling Parameters using an Innovation GA-PS Artificial Intelligence Model)

An experienced Petroleum Well Engineer with more than 11 years track of record in well engineering & operations. Seven years of operational field experience in drilling/completion & workover. In addition to his practical experience, He has a strong academic experience including around 10 years of lecturing & multidisciplinary research work with advanced analytical & numerical modelling capabilities. Currently working as a senior lecturer in Asia Pacific University while focusing on drilling and completion related modules.

Shahid Azizul Haq ('reservoir engineering while drilling' horizontal wells)

A 32 years experienced Reservoir Engineer and a distinguished SPE lecturer, who wants to foster the culture of understanding and minimizing uncertainties in our measurements and workflows, leading to a productive, profitable, and healthier oil & gas industry.

The complete event concluded with its last session on 2nd of November with live viewers upto 150, while Mr. Yohanes Nuwara's session being the most watched with upto 60 viewers. This concluded another successful collaboration by SPE APU SC which was still at its infancy being just established in March 2020.

SPE
JOINT WEBINARS SERIES
Oct-Nov 2020

Sponsored By
HUNTING

7 SPEAKERS
Technical and Career Development

Speakers:
Raffik Lazar, Dr. Rahman Ashena, Roger Findlay, Shahid Azizul Haq, Yohanes Nuwara, James Barry, Karen Ochie

Logos:
SPE International Northern Emirates Section, Asia Pacific University SPE Student Chapter

SPE Joint Webinar Series

Society of Petroleum Engineers (SPE 2020)



Asia Pacific University
SPE Student Chapter

**SYED OUBEE KHADRI
TS. HARVIN KAUR
SEPTEMBER 2020**

SPE APU SC developed a community project before ending their first term. This event was a collaboration with IEM APU Student Section and Green Ocean Movement. With a total of 16 students between both SPE APU SC and IASS, the trip was made possible on 19th September. It was made possible with the organization done by Green Ocean Movement and Mrs. Harvin Kaur.

PORT DICKSON BEACH CLEAN UP

Marking the first SPE cares initiative was vital in order to develop the student chapter to be known well in the present ecosystem of student chapters in Malaysia. This event was successful as it achieved its objective to have a community project even under the pandemic hindrance.

A total of nearly 80kg of waste materials were collected by all the groups present in the team. Although not the typical amount, but this was significant to depict the waste pollution even under pandemic conditions. GOM or Green Ocean Movement also conducted another clean up with the student chapter team last year for the same purpose.



GOM Beach Cleanup - Covid Edition

Picture gallery of Beach Clean Up Covid-19 Edition



Picture gallery of Beach Clean Up Covid-19 Edition